



Kibabii University

Tel: 020-202860/0708-085934/0734831729

E-mail vc@kibu.ac.ke

P.O Box 1699– 50200

Bungoma.

Kenya

**PROPOSED WOMEN STUDENTS HOSTEL AND ASSOCIATED WORKS
AT KIBABII UNIVERSITY.**

TENDER NO. KIBU/055/2016-2017

SPECIFICATIONS AND BILLS OF QUANTITIES

FOR

THE PROPOSED WOMEN STUDENT HOSTEL

AND ASSOCIATED WORKS

CLIENT:

The Vice Chancellor,
Kibabii University,
P.O. Box 1699-50200
Bungoma.

JUNE, 2017



INVITATION FOR TENDER

Kibabii University invites interested eligible Contractors for Proposed Women Students Hostel and Associated Works project as indicated in table below;

Tender Reference No.	Category Of Works	Registration With NCA	Bid Bond	Closing Date
KIBU/055/2016-17	Proposed Women Hostels-Main Works	NCA 2 and Above	2% Of Tender Sum	22 nd June 2017

Interested eligible Contractors may obtain further information from and inspect the tender documents in the Procurement Offices at Kibabii University during normal office working hours, Monday to Friday.

A complete set of Tender documents may be obtained by interested Contractors upon payment of nonrefundable fee of Kshs. 1,000 (One Thousands Shillings Only) deposited to;

Account name: Kibabii University
Account Number: 1132024889
Bank name: Kenya Commercial Bank
Branch name: Bungoma Branch

The pay in slip shall be taken to Finance department at Kibabii University to be issued with official receipt before collecting hard copy of the tender documents from university procurement offices during normal working hours.

OR download the tender documents from the Kibabii University website (www.kibu.ac.ke) or the IFMIS supplier portal (supplier.treasury.go.ke) free of charge.

Contactors who download the Tender documents **shall immediately** email their details and Tender number to procurement@kibu.ac.ke
Completed tender documents clearly marked “ORIGINAL” and “COPY” are to be enclosed in plain sealed envelopes, marked with the tender number only and addressed to;
**The Vice Chancellor,
Kibabii University,
P.O BOX 1699-50200,
BUNGOMA.**

Tenderer/bidders must serialize/number all the pages and copies of documents attached and indicate the documents submitted, failure to which shall lead to disqualification.

The tenders shall be deposited in the Tender Box at the entrance of Administration Block, Kibabii University Main Campus **or** if the documents don't fit in the Tender Box shall be registered and kept at the Vice Chancellors Office **or** be sent by registered mail so as to be received on or before 22nd June 2017 at 10.00am.

The tenders shall immediately after the above stated closing date and time be opened publicly in the Board Room A located on 2nd floor of Administration Block in the presence of the Contractors or their representatives who may choose to attend.

TABLE OF CONTENTS

<u>CONTENTS</u>	<u>PAGE</u>
CONTENTS PAGE.....	3
DEFINITIONS.....	4
SPECIAL NOTES.....	5
FORM OF TENDER.....	6
FORM OF TENDER SECURITY.....	7
SECTION A: INSTRUCTIONS TO TENDERERS.....	8
SECTION B: CONDITIONS OF CONTRACT.....	27
SECTION C: STANDARD FORMS.....	40
SECTION D: TENDER EVALUATION CRITERIA.....	58
SECTION E: BILLS OF QUANTITIES AND SCHEDULE OF UNITS RATES	67
DRAWINGS.....	76

DEFINITIONS

The following terms and expressions used in the contract document shall have the following meanings:

- The Employer: The Vice Chancellor,
 Kibabii University.
 P.O. Box 1699-50200
 Bungoma.
- Project Manager: To be appointed by the Client.
- Engineer: To be appointed by the Client.
- Quantity Surveyor: To be appointed by the Client.
- Employer's representative: This shall mean the Project Manager.

SPECIAL NOTES

1. These notes shall form part of the Instructions to Tenderers and Conditions of Contract.
2. The tenderer is required to check the number of pages in this document and should he find any missing, or in duplicate, or indistinct he should inform the **Procurement officer - Kibabii University**.
3. Should the tenderer be in any doubt about the precise meaning of any item or figure, for any reason whatsoever, he must inform the **Procurement officer - Kibabii University**, in order that the correct meaning may be decided before the date of submission of tender.
4. No liability will be admitted nor claim allowed, in respect of errors in the tender due to mistakes in the specification, which should have been rectified in the manner, described above.
5. All tenderers must make a declaration that they have not and will not make any payment to any person which can be perceived as an inducement to enable them to win this tender.
6. Any tenderer whose firm uses the titles “Engineer” and “Engineers” must produce evidence of registration of at least one of the directors by the Engineers Board of Kenya to avoid disqualification.

FORM OF TENDER

To: The Vice Chancellor,
Kibabii University,
P.O. Box 1699-50200
Bungoma.

Dear Sir,

Construction of the Proposed Women Student hostel and Associated Works at Kibabii University.

In accordance with the Instructions to Tenderers, Conditions of Contract, Specifications and Bills of Quantities for the execution of the above named Works, we, the undersigned offer to construct, install and complete such Works and remedy any defects therein for the sum of:

Kshs.....*[Amount in figures]*

Kenya Shillings.....
.....
.....*[Amount in words]*

We undertake, if our tender is accepted, to commence the Works as soon as is reasonably possible after the receipt of the Employer’s notice to commence, and to complete the whole of the Works comprised in the Contract within a period of forty **(40) Weeks**.

We agree to abide by this tender for **a period of 120 days from the date of tender opening** and shall remain binding upon us and may be accepted at any time before that date.

Unless and until a formal Agreement is prepared and executed this tender together with your written acceptance thereof, shall constitute a binding Contract between us.

We understand that you are not bound to accept the lowest or any tender you may receive.

Dated this day of20.....

Signature Name;

in the capacity of

duly authorized to sign tenders for and on behalf of:
.....*[Name of Tenderer]*
of.....*[Address of Tenderer]*

PIN No.

VAT CERTIFICATE No.

Witness: Name
Address
Signature

FORM OF TENDER SECURITY

WHEREAS(hereinafter called “the Tenderer”) has submitted his tender dated For the **Construction of The Proposed Women Student hostel and Associated Works at Kibabii University.**

KNOW ALL PEOPLE by these presents that WE
Having our registered office at
(hereinafter called “the Bank”), are bound unto
(hereinafter called “the Employer”) in the sum of Kshs.....
for which payment well and truly to be made to the said Employer, the Bank binds itself, its successors and assigns by these presents sealed with the Common Seal of the said Bank thisDay of20

THE CONDITIONS of this obligation are:

If after tender opening the Tenderer withdraws his tender during the period of tender validity specified in the instructions to Tenderers

Or

If the Tenderer, having been notified of the acceptance of his tender by the Employer during the period of tender validity:
fails or refuses to execute the form of Agreement in accordance with the Instructions to Tenderers, if required, or
fails or refuses to furnish the Performance Security, in accordance with the Instructions to Tenderers;

We undertake to pay to the Employer up to the above amount upon receipt of his first written demand, without the Employer having to substantiate his demand, provided that in his demand the Employer will note that the amount claimed by his is due to him, owing to the occurrence of one or both of the two conditions, specifying the occurred condition or conditions.

This guarantee will remain in force up to and including Thirty (30) days after the period of tender validity, and any demand in respect thereof should reach the Bank not later than the said date.

.....
(Date)

.....
(Signature of the Bank)

.....
(Witness)

.....
(Seal)

SECTION A:
INSTRUCTIONS TO TENDERERS.

INSTRUCTIONS TO TENDERERS

DESCRIPTION

GENERAL	PAGE
1. Definitions	11
2. Eligibility and Qualification Requirements	11
3. Cost of Tendering	12
4. Site Visit	12
 TENDER DOCUMENTS	
5. Tender Documents	13
6. Clarification of Tender Documents	13
7. Amendments of Tender Documents	13
 PREPARATION OF TENDER	
8. Language of Tender	15
9. Documents Comprising the Tender	15
10. Tender Prices	15
11. Currencies of Tender and Payment	16
12. Tender Validity	16
13. Tender Surety	17
14. No Alternative Offers	17
15. Pre-tender meeting.....	17
16. Format and Signing of Tenders	18
 SUBMISSION OF TENDERS	
17. Sealing and Marking of Tenders	19
18. Deadline and Submission of Tenders	19
19. Modification and Withdrawal of Tenders	19

TENDER OPENING AND EVALUATION

	<u>PAGE</u>
20. Tender Opening	21
21. Process to be Confidential	21
22. Clarification of Tenders	21
23. Determination of Responsiveness	22
24. Correction of Errors	22
25. Conversion to Single Currency	22
26. Evaluation and Comparison of Tenders	23

AWARD OF CONTRACT

27. Award	24
28. Notification of Award	24
29. Performance Guarantee	24
30. Advance Payment	25
Appendix to Instructions to Tenderers	26

INSTRUCTIONS TO TENDERERS

Note: The tenderer must comply with the following conditions and instructions and failure to do so is liable to result in rejection of the tender.

GENERAL

1. Definitions.

- (a) **“Tenderer”** means any person or persons partnership firm or company submitting a sum or sums in the Bills of Quantities in accordance with the Instructions to Tenderers, Conditions of Contract Parts I and II, Specifications, Drawings and Bills of Quantities for the work contemplated, acting directly or through a legally appointed representative.
- (b) **“Approved tenderer”** means the tenderer who is approved by the Employer.
- (c) Any noun or adjective derived from the word **“tender”** shall be read and construed to mean the corresponding form of the noun or adjective **“bid”**. Any conjugation of the verb “tender” shall be read and construed to mean the corresponding form of the verb “bid.”
- (d) **“Employer”** means a Central Government Ministry, Local Authority, State Corporation or any other Public Institution.

2. Eligibility and Qualification Requirements.

- 2.1 This invitation to tender is open to all tenderers who are registered with the National Construction Authority in the class stated in the tender invitation.
- 2.2 To be eligible for award of Contract, the tenderer shall provide evidence satisfactory to the Employer of their eligibility under Sub clause 2.1 above and of their capability and adequacy of resources to effectively carry out the subject Contract. To this end, the tenderer shall be required to update the following information already submitted during prequalification:-
 - (a) Details of experience and past performance of the tenderer on the works of a similar nature within the past five years and details of current work on hand and other contractual commitments.
 - (b) The qualifications and experience of key personnel proposed for administration and execution of the contract, both on and off site.
 - (c) Major items of construction plant and equipment proposed for use in carrying out the Contract. Only reliable plant in good working order and suitable for the work required of it shall be shown on this schedule. The tenderer will also indicate on this schedule when each item will be available on the Works. Included also should be a schedule of plant, equipment and material to be imported for the purpose of the Contract, giving details of make, type, origin and CIF value as appropriate.
 - (d) Details of subcontractors to whom it is proposed to sublet any portion of the Contract and for whom authority will be requested for such subletting in accordance with clause 4 of the Conditions of Contract.
 - (e) A draft Program of Works in the form of a bar chart and Schedule of Payment which shall form part of the Contract if the tender is accepted.

Any change in the Program or Schedule shall be subjected to the approval of the Engineer.

- (f) Details of any current litigation or arbitration proceedings in which the Tenderer is involved as one of the parties.

2.3 Joint Ventures

Tenders submitted by a joint venture of two or more firms as partners shall comply with the following requirements:-

- (a) The tender, and in case of a successful tender, the Form of Agreement, shall be signed so as to be legally binding on all partners.
- (b) One of the partners shall be nominated as being in charge; and this authorization shall be evidenced by submitting a power of attorney signed by legally authorized signatories of all the partners.
- (c) The partner in charge shall be authorized to incur liabilities and receive instructions for and on behalf of any and all partners of the joint venture and the entire execution of the Contract including payment shall be done exclusively with the partner in charge.
- (d) All partners of the joint venture shall be liable jointly and severally for the execution of the Contract in accordance with the Contract terms, and a relevant statement to this effect shall be included in the authorization mentioned under (b) above as well as in the Form of Tender and the Form of Agreement (in case of a successful tender).
- (e) A copy of the agreement entered into by the joint venture partners shall be submitted with the tender.

3. **Cost of Tendering.**

The Tenderer shall bear all costs associated with the preparation and submission of his tender and the Employer will in no case be responsible or liable for those costs, regardless of the conduct or outcome of the tendering process.

4. **Site Visit.**

4.1 The Tenderer is advised to visit and examine the Site and its surroundings and obtain for himself on his own responsibility, all information that may be necessary for preparing the tender and before submission of their tender. The costs of visiting the Site shall be the tenderer's own responsibility.

4.2 The Tenderer and any of his personnel or agents will be granted permission by the Employer to enter upon premises and lands for the purpose of such inspection, but only upon the express condition that the Tenderer, his personnel or agents, will release and indemnify the Employer from and against all liability in respect of, and will be responsible for personal injury (whether fatal or otherwise), loss of or damage to property and any other loss, damage, costs and expenses however caused, which but for the exercise of such permission, would not have arisen.

4.3 The Employer shall organize a site visit at a date to be notified. A representative of the Employer will be available to meet the intending tenderers at the Site. Tenderers must provide their own transport. The representative will not be available at any other time for site inspection visits. Each Tenderer shall complete the Certificate of Tenderer's Visit to the Site, whether he in fact visits the Site at the time of the organized site visit or by himself at some other time.

TENDER DOCUMENTS

5. Tender Documents

- 5.1 The Tender documents comprise the documents listed here below and should be read together with any Addenda issued in accordance with Clause 7 of these instructions to tenderers.
- a. Form of Invitation for Tenders
 - b. Instructions to Tenderers
 - c. Form of Tender
 - d. Appendix to Form of Tender
 - e. Form of Tender Surety
 - f. Statement of Foreign Currency Requirements
 - g. Form of Performance Security
 - h. Form of Agreement
 - i. Form of Advance payment Bank Guarantee
 - j. Schedules of Supplementary Information
 - k. General Conditions of Contract – Part I
 - l. Conditions of Particular Application – Part II
 - m. Specifications
 - n. Bills of Quantities
 - o. Drawings
- 5.2 The tenderer is expected to examine carefully all instructions, conditions, forms, terms, specifications and drawings in the tender documents. Failure to comply with the requirements for tender submission will be at the tenderer's own risk. Pursuant to clause 22 of Instructions to Tenderers, tenders which are not substantially responsive to the requirements of the tender documents will be rejected.
- 5.3 All recipients of the documents for the proposed Contract for the purpose of submitting a tender (whether they submit a tender or not) shall treat the details of the documents as "private and confidential".

6. Clarification of Tender Documents.

- 6.1 A prospective tenderer requiring any clarification of the tender documents may notify the Employer in writing or by telex, cable or facsimile at the Employer's mailing address indicated in the Invitation to Tender. The Employer will respond in writing to any request for clarification which he receives earlier than 28 days prior to the deadline for the submission of tenders. Written copies of the Employer's response (including the query but without identifying the source of the inquiry) will be sent to all prospective tenderers who have purchased the tender documents.

7. Amendment of Tender Documents.

- 7.1 At any time prior to the deadline for submission of tenders the Employer may, for any reason, whether at his own initiative or in response to a clarification

requested by a prospective tenderer, modify the tender documents by issuing Addenda.

- 7.2 Any Addendum will be notified in writing or by cable, telex or facsimile to all prospective tenderers who have purchased the tender documents and will be binding upon them.
- 7.3 If during the period of tendering, any circular letters (tender notices) shall be issued to tenderers by, or on behalf of, the Employer setting forth the interpretation to be placed on a part of the tender documents or to make any change in them, such circular letters will form part of the tender documents and it will be assumed that the tenderer has taken account of them in preparing his tender. The tenderer must promptly acknowledge any circular letters may receive.
- 7.4 In order to allow prospective tenderers reasonable time in which to take the Addendum into account in preparing their tenders, the Employer may, at his discretion, extend the deadline for the submission of tenders.

PREPARATION OF TENDER

8. Language of Tender.

8.1 The tender and all correspondence and documents relating to the tender exchanged between the Tenderer and the Employer shall be written in the English language. Supporting documents and printed literature furnished by the Tenderer with the tender may be in another language provided they are accompanied by an appropriate translation of pertinent passages in the above stated language. For the purpose of interpretation of the tender, the English language shall prevail.

9. Documents Comprising the Tender.

9.1 The tender to be prepared by the Tenderer shall comprise: the Form of Tender and Appendix thereto, a Tender Surety, the Priced Bills of Quantities and Schedules, the information on eligibility and qualification, and any other materials required to be completed and submitted in accordance with the Instructions to Tenderers embodied in these tender documents. The Forms, Bills of Quantities and Schedules provided in the tender documents shall be used without exception (subject to extensions of the schedules in the same format and to the provisions of clause 13.2 regarding the alternative forms of Tender Surety].

10. Tender Prices

10.1 All the insertions made by the Tenderer shall be made in **INK** and the tenderer shall clearly form the figures. The relevant space in the Form of Tender and Bills of Quantities shall be completed accordingly without interlineations or erasures except those necessary to correct errors made by the Tenderer in which case the erasures and interlineations shall be initialed by the person or persons signing the tender.

10.2 A price or rate shall be inserted by the Tenderer for every item in the Bills of Quantities whether the quantities are stated or not items against which no rate or price is entered by the Tenderer will not be paid for by the Employer when executed and shall be deemed covered by the rates for other items and prices in the Bills of Quantities.

-The prices and unit rates in the Bills of Quantities are to be the full [all-inclusive] value of the work described under the items, including all costs and expenses which may be necessary and all general risks, liabilities and obligations set forth or implied in the documents on which the tender is based. All duties and taxes and other levies payable by the Contractor under the Contract or for any other cause as of the date 28 days prior to the deadline for the submission of tenders, shall be included in the rates and prices and the total tender prices submitted by the Tenderer.

Each price or unit rate inserted in the Bills of Quantities should be a realistic estimate for completing the activity or activities described under that particular item and the Tenderer is advised against inserting a price or rate against any item contrary to this instruction.

Every rate entered in the Bills of Quantities, whether or not such rate be associated with a quantity, shall form part of the Contract. The Employer shall have the right to call for any item of work contained in the Bills of Quantities,

and such items of work to be paid for at the rate entered by the Tenderer and it is the intention of the Employer to take full advantage of unbalanced low rates.

- 10.3 Unless otherwise specified the Tenderer must enter the amounts representing 10% of the sub-total of the summary of the Bills of Quantities for Contingencies and Variation of Prices [V.O.P.] payments in the summary sheet and add them to the sub-total to arrive at the tender amount.
- 10.4 The Tenderer shall furnish with his tender written confirmation from his suppliers or manufacturers of unit rates for the supply of items listed in the Conditions of Contract clause 47 where appropriate.
- 10.5 The rates and prices quoted by the Tenderer are subject to adjustment during the performance of the Contract only in accordance with the provisions of the Conditions of Contract. The Tenderer shall complete the schedule of basic rates and shall submit with his tender such other supporting information as required under clause 47 of the Conditions of Contract Part II.

11. Currencies of Tender and Payment.

- 11.1 Tenders shall be priced in Kenya Shillings and the tender sum shall be in Kenya Shillings.
- 11.2 Tenderers are required to indicate in the Statement of Foreign Currency Requirements, which forms part of the tender, the foreign currency required by them. Such currency should generally be the currency of the country of the Tenderer's main office. However, if a substantial portion of the Tenderer's expenditure under the Contract is expected to be in countries other than his country of origin, then he may state a corresponding portion of the contract price in the currency of those other countries. However, the foreign currency element is to be limited to two (2) different currencies and a maximum of 30% (thirty percent) of the Contract Price.
- 11.3 The rate of rates of exchange used for pricing the tender shall be selling rate or rates of the Central Bank ruling on the date thirty (30) days before the final date for the submission of tenders.
- 11.4 Tenderers must enclose with their tenders, a brief justification of the foreign currency requirements stated in their tenders.

12. Tender Validity.

- 12.1 The tender shall remain valid and open for acceptance for a period of one hundred and twenty (120) days from the specified date of tender opening or from the extended date of tender opening (in accordance with clause 7.4 here above) whichever is the later.
- 12.2 In exceptional circumstances prior to expiry of the original tender validity period, the Employer may request the Tenderer for a specified extension of the period of validity. The request and the responses thereto shall be made in writing or by cable, telex or facsimile. A Tenderer may refuse the request without forfeiting his Tender Surety. A Tenderer agreeing to the request will not be required nor permitted to modify his tender, but will be required to extend the validity of his Tender Surety correspondingly.

13. Tender Surety.

- 13.1 The Tenderer shall furnish as part of his tender, a Tender Surety in the amount stated in the Appendix to Instructions to Tenderers.
- 13.2 The unconditional Tender Surety shall be in Kenya Shillings and be in form of a certified cheque, a bank draft, an irrevocable letter of credit or a guarantee from a reputable Bank or insurance company registered by Insurance Regulatory Authority, located in the Republic of Kenya and approved by the Employer.

The format of the Surety shall be in accordance with the sample form of Tender Surety included in these tender documents; other formats may be permitted subject to the prior approval of the Employer. The Tender Surety shall be valid for twenty eight (28) days beyond the tender validity period.

- 13.3 Any tender not accompanied by an acceptable Tender Surety will be rejected by the Employer as non-responsive.
- 13.4 The Tender Sureties of unsuccessful tenderers will be returned as promptly as possible but not later than twenty eight (28) days after concluding the Contract execution and after a Performance Security has been furnished by the successful Tenderer. The Tender Surety of the successful Tenderer will be returned upon the Tenderer executing the Contract and furnishing the required Performance Security.
- 13.5 The Tender Surety may be forfeited:
- (a) if a Tenderer withdraws his tender during the period of tender validity: or
 - (b) in the case of a successful Tenderer, if he fails
 - (i) to sign the Agreement, or
 - (ii) to furnish the necessary Performance Security.
 - (c) if a Tenderer does not accept the correction of his tender price pursuant to clause 23.

14. No Alternative Offers.

- 14.1 The Tenderer shall submit an offer, which complies fully with the requirements of the tender documents.
Only one tender may be submitted by each Tenderer either by himself or as partner in a joint venture.
- 14.2 The Tenderer shall not attach any conditions of his own to his tender. The tender price must be based on the tender documents. The Tenderer is not required to present alternative construction options and he shall use without exception, the Bills of Quantities as provided, with the amendments as notified in tender notices, if any, for the calculation of his tender price.
-Any Tenderer who fails to comply with this clause will be disqualified.

15. Pre-Tender Meeting

- 15.1 The Tenderer's designated representative is invited to attend a pre-tender meeting, which if convened, will take place at the venue and time stated in the Invitation to Tender. The purpose of the meeting will be to clarify issues and to answer questions on any matter that may be raised at that stage.
- 15.2 The Tenderer is requested as far as possible to submit any questions in writing or by cable, to reach the Employer not later than seven days before the meeting. It

may not be practicable at the meeting to answer questions received late, but questions and responses will be transmitted in accordance with the following:

- (a) Minutes of the meeting, including the text of the questions raised and the responses given together with any responses prepared after the meeting, will be transmitted without delay to all purchasers of the tender documents. Any modification of the tender documents listed in --Clause 9 which may become necessary as a result of the pre-tender meeting shall be made by the Employer exclusively through the issue of a tender notice pursuant to Clause 7 and not through the minutes of the pre-tender meeting.

- (b) Non-attendance at the pre-tender meeting will not be cause for disqualification of a bidder.

16. Format and Signing of Tenders.

- 16.1 The Tenderer shall prepare his tender as outlined in clause 9 above and mark appropriately one set “**ORIGINAL**” and the other “**COPY**”.
- 16.2 The copy of the tender and Bills of Quantities shall be typed or written in indelible ink and shall be signed by a person or persons duly authorized to sign on behalf of the Tenderer. Proof of authorization shall be furnished in the form of the written power of attorney which shall accompany the tender. All pages of the tender where amendments have been made shall be initialed by the person or persons signing the tender.
- 16.3 The complete tender shall be without alterations, interlineations or erasures, except as necessary to correct errors made by the Tenderer, in which case such corrections shall be initialed by the person or persons signing the tender.

SUBMISSION OF TENDERS

17. Sealing and Marking of Tenders.

- 17.1 The Tenderer shall seal the original and copy of the tender in separated envelopes, duly marking the envelopes as **“ORIGINAL” and “COPY”**. The envelopes shall then be sealed in an outer envelope.
- 17.2 The inner and outer envelopes shall be addressed to the Employer at the address stated in the Appendix to Instructions to Tenderers and bear the name and identification of the Contract stated in the said Appendix with a warning not to open before the date and time for opening of tenders stated in the said Appendix.
- 17.3 The inner envelopes shall each indicated the name and address of the Tenderer to enable the tender to be returned unopened in case it is declared “late”, while the outer envelope shall bear no mark indicating the identity of the Tenderer.
- 17.4 If the outer envelope is not sealed and marked as instructed above, the Employer will assume no responsibility for the misplacement or premature opening of the tender. A tender opened prematurely for this cause will be rejected by the Employer and returned to the Tenderer.

18 Deadline for Submission of Tenders.

- 18.1 Tenders must be received by the Employer at the address specified in clause 17.2 and on the date and time specified in the Letter of Invitation, subject to the provisions of clause 7.4, 18.2 and 18.3.
Tenders delivered by hand must be placed in the “tender box” provided in the office of the Employer.

Proof of posting will not be accepted as proof of delivery and any tender delivered after the above stipulated time, from whatever cause arising will not be considered.
- 18.2 The Employer may, at his discretion, extend the deadline for the submission of tenders through the issue of an Addendum in accordance with clause 7, in which case all rights and obligations of the Employer and the tenderers previously subject to the original deadline shall thereafter be subject to the new deadline as extended.
- 18.3 Any tender received by the Employer after the prescribed deadline for submission of tender will be returned unopened to the Tenderer.

19 Modification and Withdrawal of Tenders.

- 19.1 The Tenderer may modify or withdraw his tender after tender submission, provided that written notice of the modification or withdrawal is received by the Employer prior to prescribed deadline for submission of tenders.
- 19.2 The Tenderer’s modification or withdrawal notice shall be prepared, sealed, marked and dispatched in accordance with the provisions for the submission of tenders, with the inner and outer envelopes additionally mark “MODIFICATION” or “WITHDRAWAL” as appropriate.
- 19.3 No tender may be modified subsequent to the deadline for submission of tenders.

- 19.4 No tender may be withdrawn in the interval between the deadline for submission of tenders and the period of tender validity specified on the tender form. Withdrawal of a tender during this interval will result in the forfeiture of the Tender Surety.
- 19.5 Subsequent to the expiration of the period of tender validity prescribed by the Employer, and the Tenderer having not been notified by the Employer of the award of the Contract or the Tenderer does not intend to conform with the request of the Employer to extend the period of tender validity, the Tenderer may withdraw his tender without risk of forfeiture of the Tender Surety.

TENDER OPENING AND EVALUATION

20 Tender Opening.

- 20.1 The Employer will open the tenders in the presence of the tenderers' representatives who choose to attend at the time and location indicated in the Letter of Invitation to Tender. The tenderers' representatives who are present shall sign a register evidencing their attendance.
- 20.2 Tenders for which an acceptable notice of withdrawal has been submitted, pursuant to clause 19, will not be opened. The Employer will examine the tenders to determine whether they are complete, whether the requisite Tender Sureties have been furnished, whether the documents have been properly signed and whether the tenders are generally in order.
- 20.3 At the tender opening, the Employer will announce the Tenderer's names, total tender price, tender price modifications and tender withdrawals, if any, the presence of the requisite Tender Surety and such other details as the Employer, at his discretion, may consider appropriate. No tender shall be rejected at the tender opening except for late tenders.
- 20.4 The Employer shall prepare minutes of the tender opening including the information disclosed to those present.
- 20.5 Tenders not opened and read out a tender opening shall not be considered further for evaluation, irrespective of the circumstances.

21 Process to be Confidential.

- 21.1 After the public opening of tenders, information relating to the examination, clarification, evaluation and comparisons of tenders and recommendations concerning the award of Contract shall not be disclosed to tenderers or other persons not officially concerned with such process until the award of Contract is announced.
- 21.2 Any effort by a Tenderer to influence the Employer in the process of examination, evaluation and comparison of tenders and decisions concerning award of Contract may result in the rejection of the Tenderer's tender.

22 Clarification of Tenders.

- 22.1 To assist in the examination, evaluation and comparison of tenders, the Employer may ask tenderers individually for clarification of their tenders, including breakdown of unit prices. The request for clarification and the response shall be in writing or by cable, facsimile or telex, but no change in the price or substance of the tender shall be sought, offered or permitted except as required to confirm the correction of arithmetical errors discovered by the employer during the evaluation of the tenders in accordance with clause 24.
- 22.2 No Tenderer shall contact the Employer on any matter relating to his tender from the time of the tender opening to the time the Contract is awarded. If the tenderer wishes to bring additional information to the notice of the Employer, he shall do so in writing.

23 Determination of Responsiveness.

- 23.1 Prior to the detailed evaluation of tenders, the Employer will determine whether each tender is substantially responsive to the requirements of the tender documents.
- 23.2 For the purpose of this clause, a substantially responsive tender is one which conforms to all the terms, conditions and specifications of the tender documents without material deviation or reservation and has a valid bank guarantee. A material deviation or reservation is one which affects in any substantial way the scope, quality, completion timing or administration of the Works to be undertaken by the tenderer under the Contract, or which limits in any substantial way, inconsistent with the tender documents, the Employer's rights or the tenderers obligations under the Contract and the rectification of which would affect unfairly the competitive position of other tenderers who have presented substantially responsive tenders.
- 23.3 Each price or unit rate inserted in the Bills of Quantities shall be a realistic estimate of the cost of completing the works described under the particular item including allowance for overheads, profits and the like. Should a tender be seriously unbalanced in relation to the Employer's estimate of the works to be performed under any item or groups of items, the tender shall be deemed not responsive.
- 23.4 A tender determined to be not substantially responsive will be rejected by the Employer and may not subsequently be made responsive by the Tenderer by correction of the non-conforming deviation or reservation.

24 Correction of Errors.

Tenders determined to be substantially responsive shall be checked by the Employer for any arithmetic errors in the computations and summations. Errors will be corrected by the Employer as follows:

- (a) Where there is a discrepancy between the amount in figures and the amount in words, the amount in words will govern.
- (b) Where there is a discrepancy between the unit rate and the line item total resulting from multiplying the unit rate by the quantity, the unit rate as quoted will prevail, unless in the opinion of the Employer, there is an obvious typographical error, in which case adjustment will be made to the entry containing that error.
- (c) The amount stated in the tender will be adjusted in accordance with the above procedure for the correction of errors and, with concurrence of the Tenderer, shall be considered as binding upon the Tenderer. If the Tenderer does not accept the corrected amount, the tender may be rejected and the Tender Security may be forfeited in accordance with clause 13.

25 Conversion to Single Currency.

- 25.1 For compensation of tenders, the tender price shall first be broken down into the respective amounts payable in various currencies by using the selling rate or rates of the Central Bank of Kenya ruling on the date twenty eight (28) days before the final date for the submission of tenders.

- 25.2 The Employer will convert the amounts in various currencies in which the tender is payable (excluding provisional sums but including Day works where priced competitively) to Kenya Shillings at the selling rates stated in clause 25.1.

26 Evaluation and Comparison of Tenders.

- 26.1 The Employer will evaluate only tenders determined to be substantially responsive to the requirements of the tender documents in accordance with clause 23.
- 26.2 In evaluating tenders, the Employer will determine for each tender the evaluated tender price by adjusting the tender price as follows:
- (a) Making any correction for errors pursuant to clause 24.
 - (b) Excluding Provisional Sums and provision, if any, for Contingencies in the Bills of Quantities, but including Day works where priced competitively.
- 26.3 The Employer reserves the right to accept any variation, deviation or alternative offer. Variations, deviations, alternative offers and other factors which are in excess of the requirements of the tender documents or otherwise result in the accrual of unsolicited benefits to the Employer, shall not be taken into account in tender evaluation.
- 26.4 Price adjustment provisions in the Conditions of Contract applied over the period of execution of the Contract shall not be taken into account in tender evaluation.
- 26.5 If the lowest evaluated tender is seriously unbalanced or front loaded in relation to the Employer's estimate of the items of work to be performed under the Contract, the Employer may require the Tenderer to produce detailed price analyses for any or all items of the Bills of Quantities, to demonstrate the relationship between those prices, proposed construction methods and schedules. After evaluation of the price analyses, the Employer may require that the amount of the Performance Security set forth in clause 29 be increased at the expense of the successful Tenderer to a level sufficient to protect the Employer against financial loss in the event of subsequent default of the successful Tenderer under the Contract.
- 26.6 Firms incorporated in Kenya where indigenous Kenyans own 51% or more of the share capital shall be allowed a 10% preferential bias provided that they do not sub-contract work valued at more than 50% of the Contract Price excluding Provisional Sums to a non-indigenous sub-contractor.

AWARD OF CONTRACT

27 **Award.**

- 27.1 Subject to clause 27.2, the Employer will award the Contract to the Tenderer whose tender is determined to be substantially responsive to the tender documents and who has offered the lowest evaluated tender price subject to possessing the capability and resources to effectively carry out the Contract Works.
- 27.2 The Employer reserves the right to accept or reject any tender, and to annul the tendering process and reject all tenders, at any time prior to award of Contract, without thereby incurring any liability to the affected tenderers or any obligation to inform the affected tenderers of the grounds for the Employer's action.

28 **Notification of Award.**

- 28.1 Prior to the expiration of the period of tender validity prescribed by the Employer, the Employer will notify the successful Tenderer by cable, telefax or telex and confirmed in writing by registered letter that his tender has been accepted. This letter (hereinafter and in all Contract documents called "Letter of Acceptance") shall name the sum (hereinafter and in all Contract documents called "the Contract Price"), which the Employer will pay to the Contractor in consideration of the execution and completion of the Works as prescribed by the Contract.
- 28.2 Notification of award will constitute the formation of the Contract.
- 28.3 Upon the furnishing of a Performance Security by the successful Tenderer, the unsuccessful tenderers will promptly be notified that their tenders have been unsuccessful.
- 28.4 Within twenty-eight [28] days of receipt of the form of Contract Agreement from the Employer, the successful Tenderer shall sign the form and return it to the Employer together with the required Performance Security.

29 **Performance Guarantee.**

- 29.1 Within twenty eight [28] days of receipt of the notification of award from the Employer, the successful Tenderer shall furnish the Employer with a Performance Security in an amount stated in the Appendix to Instructions to Tenderers.
- 29.2 The Performance Security to be provided by the successful Tenderer shall be an unconditional Bank Guarantee issued at the Tenderer's option by an established and a reputable Bank approved by the Employer and located in the Republic of Kenya and shall be divided into two elements namely, a performance security payable in foreign currencies (based upon the exchange rates determined in accordance with clause 35.4 of the Conditions of Contract) and a performance security payable in Kenya Shillings. The value of the two securities shall be in the same proportions of foreign and local currencies as requested in the form of foreign currency requirements.

29.3 Failure of the successful Tenderer to lodge the required Performance Security shall constitute a breach of Contract and sufficient grounds for the annulment of the award and forfeiture of the Tender Security and any other remedy under the Contract the Employer may award the Contract to the next ranked Tenderer.

30 Advance Payment.

An advance payment, if approved by the Employer, shall be made under the Contract, if requested by the Contractor, in accordance with clause 33.1 of the Conditions of Contract. The Advance Payment Guarantee shall be denominated in the proportion and currencies named in the form of foreign currency requirements. For each currency, a separate guarantee shall be issued. The guarantee shall be issued by a bank located in the Republic of Kenya, or a foreign bank through a correspondent bank located in the Republic of Kenya, in either case subject to the approval of the Employer.

APPENDIX TO INSTRUCTIONS TO TENDERERS

1. CLAUSE 2.1

Change to read, “This invitation to Tender is open to all tenderers in the category specified.”

2. OMIT

Clauses 5.1 (a), (f), (i), (j),10.3,10.4,11.2, 11.3,11.4,15,25,26.6,30

3. ADD TO CLAUSE 7.2

Tender documents purchased or downloaded and tenderer registered with the Procurement Officer, Kibabii University.

3. ADD TO CLAUSE 13.1

Amount of tender surety will be **Two Per Cent (2%) of Tender Sum**

4. ADD TO 29.1CLAUSE

Amount of performance security will be **Seven Per Cent (7%) of Tender Sum.**

5. ADD TO CLAUSE 29.2

Performance security shall not be divided in two elements and shall be payable in Kenya Shillings Only.

6. ADD TO CLAUSE 13.2

Tender security to be valid for 30 days beyond Tender Validity period.

7. ADD TO CLAUSE 18.1.

The tenders shall be deposited in the Tender Box at the entrance of Administration Block, Kibabii University Main Campus or if the documents don't fit in the Tender Box shall be registered and kept at the Vice Chancellors Office or be sent by registered mail.

8. ADD TO CLAUSE 24

- (i) In the event of a discrepancy between the tender amount as stated in the form of tender and the corrected tender figure in the main summary of the bills of quantities the amount as stated in the form of tender shall prevail.
- (ii) The correction factor shall be computed by expressing the difference between the amount and the corrected tender sum as a percentage of the corrected sub-contact works. (i.e. corrected tender sum less PC and provisional sums)
- (iii) form of tender and the corrected tender figure in the main summary of the bills of quantities the amount as stated in the form of tender shall prevail.
- (iv) The correction factor shall be computed by expressing the difference between the amount and the corrected tender sum as a percentage of the corrected sub-contact works. (i.e. corrected tender sum less PC and provisional sums)
- (v) The error correction factor shall be applied to all sub-contract works (as a rebate or addition as the case may be) for the purposes of valuations for interim certificates and valuation

SECTION B

CONDITIONS OF CONTRACT

CONDITIONS OF CONTRACT

CONTENTS

CLAUSE NO.	PAGE
1. DEFINITIONS.....	30
2. CONTRACT DOCUMENTS.....	31
3. EMPLOYER’S REPRESENTATIVE’S DECISIONS.....	31
4. WORKS, LANGUAGE AND LAW OF CONTRACT.....	31
5. SAFETY, TEMPORARY WORKS AND DISCOVERIES.....	32
6. WORK PROGRAMME AND SUB-CONTRACTING.....	32
7. THE SITE.....	32
8. INSTRUCTIONS.....	32
9. EXTENSION OF COMPLETION DATE.....	32
10. MANAGEMENT MEETINGS.....	33
11. DEFECTS.....	33
12. BILLS OF QUANTITIES/SCHEDULE OF RATES.....	34
13. VARIATIONS.....	34
14. PAYMENT CERTIFICATES AND FINAL ACCOUNT	35
15. INSURANCES.....	35

16.	LIQUIDATED DAMAGES.....	36
17.	COMPLETION AND TAKING OVER.....	36
18.	TERMINATION.....	36
19.	PAYMENT UPON TERMINATION.....	37
20.	CORRUPT GIFTS AND PAYMENTS OF COMMISSION.....	37
21.	SETTLEMENT OF DISPUTES.....	37
	APPENDIX TO CONDITIONS OF CONTRACT	38

CONDITIONS OF CONTRACT

1. Definitions

1.1 In this Contract, except where context otherwise requires, the following terms shall be interpreted as indicated;

“Bills of Quantities” means the priced and completed Bill of Quantities forming part of the tender [where applicable].

“Schedule of Rates” means the priced Schedule of Rates forming part of the tender [where applicable].

“The Completion Date” means the date of completion of the Works as certified by the Employer’s Representative.

“The Contract” means the agreement entered into by the Employer and the Contractor as recorded in the Agreement Form and signed by the parties.

“The Contractor” refers to the person or corporate body whose tender to carry out the Works has been accepted by the Employer.

“The Contractor’s Tender” is the completed tendering document submitted by the Contractor to the Employer.

“The Contract Price” is the price stated in the Letter of Acceptance.

“Days” are calendar days; **“Months”** are calendar months.

“A Defect” is any part of the Works not completed in accordance with the Contract.

“The Defects Liability Certificate” is the certificate issued by Employer’s Representative upon correction of defects by the Contractor.

“The Defects Liability Period” is the period named in the Appendix to Conditions of Contract and calculated from the Completion Date.

“Drawings” include calculations and other information provided or approved by the Employer’s Representative for the execution of the Contract.

“Employer” includes Central or Local Government administration, Universities, Public Institutions and Corporations and is the party who employs the Contractor to carry out the Works.

“Equipment” is the Contractor’s machinery and vehicles brought temporarily to the Site for the execution of the Works.

“Site” means the place or places where the permanent Works are to be carried out including workshops where the same is being prepared.

“**Materials**” are all supplies, including consumables, used by the Contractor for incorporation in the Works.

“**Employer’s Representative**” is the person appointed by the Employer and notified to the Contractor for the purpose of supervision of the Works.

“**Specification**” means the Specification of the Works included in the Contract.

“**Start Date**” is the date when the Contractor shall commence execution of the Works.

“**A Sub-contractor**” is a person or corporate body who has a Contract with the Contractor to carry out a part of the Work in the Contract, which includes Work on the Site.

“**Temporary works**” are works designed, constructed, installed, and removed by the Contractor which are needed for construction or installation of the Works.

“**A Variation**” is an instruction given by the Employer’s Representative which varies the Works.

“**The Works**” are what the Contract requires the Contractor to construct, install, and turnover to the Employer.

2. Contract Documents

2.1 The following documents shall constitute the Contract documents;

- (1) Agreement,
- (2) Letter of Acceptance,
- (3) Contractor’s Tender,
- (4) Conditions of Contract,
- (5) Specifications,
- (6) Drawings,
- (7) Bills of Quantities or Schedule of Rates [whichever is applicable]

3. Employer’s Representative’s Decisions.

3.1 Except where otherwise specifically stated, the Employer’s Representative will decide contractual matters between the Employer and the Contractor in the role representing the Employer.

4. Works, Language and Law of Contract.

4.1 The Contractor shall construct and install the Works in accordance with the Contract documents. The Works may commence on the Start Date and shall be carried out in accordance with the Programme submitted by the Contractor, as updated with the approval of the Employer’s Representative, and complete them by the Intended Completion Date.

4.2 The ruling language of the Contract shall be English language and the law governing the Contract shall be the law of the Republic of Kenya.

5. Safety, Temporary works and Discoveries.

- 5.1 The Contractor shall be responsible for design of temporary works and shall obtain approval of third parties to the design of the temporary works where required.
- 5.2 The Contractor shall be responsible for the safety of all activities on the Site.
- 5.3 Anything of historical or other interest or significant value unexpectedly discovered on the Site shall be the property of the Employer. The Contractor shall notify the Employer's Representative of such discoveries and carry out the Employer's Representative's instructions for dealing with them.

6. Work Programme and Sub-contracting

- 6.1 Within seven days after Site possession date, the Contractor shall submit to the Employer's Representative for approval a programme showing the general methods, arrangements, order and timing for all the activities in the Works.
- 6.2 The Contractor may sub-contract the Works (but only to a maximum of 25 percent of the Contract Price) with the approval of the Employer's Representative. However, he shall not assign the Contract without the approval of the Employer in writing. Sub-contracting shall not alter the Contractor's obligations.

7. The site.

- 7.1 The Employer shall give possession of all parts of the Site to the Contractor.
- 7.2 The Contractor shall allow the Employer's Representative and any other person authorized by the Employer's Representative, access to the Site and to any place where work in connection with the Contract is being carried out or is intended to be carried out.

8. Instructions.

- 8.1 The Contractor shall carry out all instructions of the Employer's Representative which are in accordance with the Contract.

9. Extension of Completion Date.

- 9.1 The Employer's Representative shall extend the Completion Date if an occurrence arises which makes it impossible for completion to be achieved by the Intended Completion Date. The Employer's Representative shall decide whether and by how much to extend the Completion Date.
- 9.2 For the purposes of this Clause, the following occurrences shall be valid for consideration;

Delay by:-

- (a) force majeure, or
- (b) reason of any exceptionally adverse weather conditions, or

- (c) reason of civil commotion, strike or lockout affecting any of the trades employed upon the Works or any of the trades engaged in the preparation, manufacture or transportation of any of the goods or materials required for the Works, or
- (d) reason of the Employer's Representative's instructions issued under these Conditions, or
- (e) reason of the contractor not having received in due time necessary instructions, drawings, details or levels from the Employer's Representative for which he specifically applied in writing on a date which having regard to the date for Completion stated in the appendix to these Conditions or to any extension of time then fixed under this Clause was neither unreasonably distant from nor unreasonably close to the date on which it was necessary for him to receive the same, or
- (f) delay on the part of artists, tradesmen or others engaged by the Employer in executing work not forming part of this Contract, or
- (g) reason of delay by statutory or other services providers or similar bodies engaged directly by the Employer, or
- (h) reason of opening up for inspection of any Work covered up or of the testing or any of the Work, materials or goods in accordance with these conditions unless the inspection or test showed that the Work, materials or goods were not in accordance with this Contract, or
- (i) reason of delay in appointing a replacement Employer's Representative, or
- (j) reason of delay caused by the late supply of goods or materials or in executing Work for which the Employer or his agents are contractually obliged to supply or to execute as the case may be, or
- (k) delay in receiving possession of or access to the Site.

10. Management Meetings.

- 10.1 A Contract management meeting shall be held regularly and attended by the Employer's Representative and the Contractor. Its business shall be to review the plans for the remaining Work. The Employer's Representative shall record the business of management meetings and provide copies of the record to those attending the meeting and the Employer. The responsibility of the parties for actions to be taken shall be decided by the Employer's Representative either at the management meeting or after the management meeting and stated in writing to all who attend the meeting.
- 10.2 Communication between parties shall be effective only when in writing.

11. Defects.

- 11.1 The Employer's Representative shall inspect the Contractor's work and notify the Contractor of any defects that are found. Such inspection shall not affect the Contractor's responsibilities. The Employer's Representative may instruct the

Contractor to search for a defect and to uncover and test any Work that the Employer's Representative considers may have a defect. Should the defect be found, the cost of uncovering and making good shall be borne by the Contractor. However, if there is no defect found, the cost of uncovering and making good shall be treated as a variation and added to the Contract Price.

- 11.2 The Employer's Representative shall give notice to the Contractor of any defects before the end of the Defects Liability Period, which begins at Completion, and is defined in the Appendix to Conditions of Contract.
- 11.3 Every time notice of a defect is given, the Contractor shall correct the notified defect within the length of time specified by the Employer's Representative's notice. If the Contractor has not corrected a defect within the time specified in the Employer's Representative's notice, the Employer's Representative will assess the cost of having the defect corrected by other parties and such cost shall be treated as a variation and be deducted from the Contract Price.

12. Bills of Quantities/Schedule of Rates.

- 12.1 The Bills of Quantities/Schedule of Rates shall contain items for the construction, installation, testing and commissioning of the Work to be done by the Contractor. The Contractor will be paid for the quantity of the Work done at the rates in the Bills of Quantities/Schedule of Rates for each item. Items against which no rate is entered by the Tenderer will not be paid for when executed and shall be deemed covered by the rates for other items in the Bills of Quantities/Schedule of Rates.
- 12.2 Where Bills of Quantities do not form part of the Contract, the Contract Price shall be a lump sum (which shall be deemed to have been based on the rates in the Schedule of Rates forming part of the tender) and shall be subject to re-measurement after each stage.

13. Variations.

- 13.1 The Contractor shall provide the Employer's Representative with a quotation for carrying out the variations when requested to do so. The Employer's Representative shall assess the quotation and shall obtain the necessary authority from the Employer before the variation is ordered.
- 13.2 If the Work in the variation corresponds with an item description in the Bill of Quantities/Schedule of Rates, the rate in the Bill of Quantities/Schedule of Rates shall be used to calculate the value of the variation. If the nature of the Work in the variation does not correspond with items in the Bill of Quantities/Schedule of Rates, the quotation by the Contractor shall be in the form of new rates for the relevant items of Work.
- 13.3 If the Contractor's quotation is unreasonable, the Employer's Representative may order the variation and make a change to the Contract Price, which shall be based on the Employer's Representative's own forecast of the effects of the variation on the Contractor's costs.

14. Payment Certificates and Final Account

- 14.1 The Contractor shall be paid after each of the following stages of Work listed here below (subject to re-measurement by the Employer's Representative of the Work done in each stage before payment is made). In case of lump-sum Contracts, the valuation for each stage shall be based on the quantities so obtained in the re-measurement and the rates in the Schedule of Rates.
- (i) Advance payment - **No advance shall be paid.**
 - (ii) First stage (*define stage*) **AS PER PROGRESS**
 - (iii) Second stage (*define stage*) **AS PER PROGRESS**
 - (iv) Third stage (*define stage*) **AS PER PROGRESS**
 - (v) After defects liability period.
- 14.2 Upon deciding that Works included in a particular stage are complete, the Contractor shall submit to the Employer's Representative his application for payment. The Employer's Representative shall check, adjust if necessary and certify the amount to be paid to the Contractor within 21 days of receipt of the Contractor's application. The Employer shall pay the Contractor the amounts so certified within 30 days of the date of issue of each Interim Certificate.
- 14.3 The Contractor shall supply the Employer's Representative with a detailed final account of the total amount that the Contractor considers payable under the Contract before the end of the Defects Liability Period. The Employer's Representative shall issue a Defect Liability Certificate and certify any final payment that is due to the Contractor within 30 days of receiving the Contractor's account if it is correct and complete. If it is not, the Employer's Representative shall issue within 21 days a schedule that states the scope of the corrections or additions that are necessary. If the final account is still unsatisfactory after it has been resubmitted, the Employer's Representative shall decide on the amount payable to the Contractor and issue a Final Payment Certificate. The Employer shall pay the Contractor the amount so certified within 60 days of the issue of the Final Payment Certificate.
- 14.4 If the period laid down for payment to the Contractor upon each of the Employer's Representative's Certificate by the Employer has been exceeded, the Contractor shall be entitled to claim simple interest calculated pro-rata on the basis of the number of days delayed at the Central Bank of Kenya's average base lending rate prevailing on the first day the payment becomes overdue. The Contractor will be required to notify the Employer within 15 days of receipt of delayed payments of his intentions to claim interest.

15. Insurance.

- 15.1 The Contractor shall be responsible for and shall take out appropriate cover against, among other risks, personal injury; loss of or damage to the Works, materials and plant; and loss of or damage to property.

16. Liquidated Damages.

16.1 The Contractor shall pay liquidated damages to the Employer at the rate 0.001 per cent of the Contract price per day for each day that the actual Completion Date is later than the Intended Completion Date except in the case of any of the occurrences listed under Clause 9.2. The Employer may deduct liquidated damages from payments due to the Contractor. Payment of liquidated damages shall not affect the Contractor's liabilities.

17. Completion and Taking Over.

17.1 Upon deciding that the Work is complete the Contractor shall request the Employer's Representative to issue a Certificate of Completion of the Works, upon deciding that the Work is completed.

The Employer shall take over the Site and the Works within seven days of the Employer's Representative issuing a Certificate of Completion.

18. Termination.

18.1 The Employer or the Contractor may terminate the Contract if the other party causes a fundamental breach of the Contract. These fundamental breaches of Contract shall include, but shall not be limited to, the following;

- (a) the Contractor stops Work for 30 days continuously without reasonable cause or authority from the Employer's Representative;
- (b) the Contractor is declared bankrupt or goes into liquidation other than for a reconstruction or amalgamation;
- (c) a payment certified by the Employer's Representative is not paid by the Employer to the Contractor within 30 days after the expiry of the payment periods stated in Sub-Clauses 14.2 and 14.3 here above.
- (d) the Employer's Representative gives notice that failure to correct a particular defect is a fundamental breach of Contract and the Contractor fails to correct it within a reasonable period of time.

18.2 If the Contract is terminated, the Contractor shall stop Work immediately, and leave the Site as soon as reasonably possible. The Employer's Representative shall immediately thereafter arrange for a meeting for the purpose of taking record of the Works executed and materials, goods, equipment and temporary buildings on Site.

19. Payment Upon Termination.

- 19.1 The Employer may employ and pay other persons to carry out and complete the Works and to rectify any defects and may enter upon the Works and use all materials on Site, plant, equipment and temporary works.
- 19.2 The Contractor shall, during the execution or after the completion of the Works under this Clause, remove from the Site as and when required within such reasonable time as the Employer's Representative may in writing specify, any temporary buildings, plant, machinery, appliances, goods or materials belonging to him, and in default thereof, the Employer may (without being responsible for any loss or damage) remove and sell any such property of the Contractor, holding the proceeds less all costs incurred to the credit of the Contractor.
- 19.3 Until after completion of the Works under this Clause, the Employer shall not be bound by any other provision of this Contract to make any payment to the Contractor, but upon such completion as aforesaid and the verification within a reasonable time of the accounts there for the Employer's Representative shall certify the amount of expenses properly incurred by the Employer and, if such amount added to the money paid to the Contractor before such determination exceeds the total amount which would have been payable on due completion in accordance with this Contract, the difference shall be a debt payable to the Employer by the Contractor; and if the said amount added to the said money be less than the said total amount, the difference shall be a debt payable by the Employer to the Contractor.

20. Corrupt Gifts and Payments of Commission

- 20.1 The Contractor shall not:
- (a) Offer or give or agree to give to any person in the service of the Employer any gifts or consideration of any kind as an inducement or reward for doing or forbearing to do or for having done or forborne to do any act in relation to the obtaining or execution of this or any other contract with the Employer or for showing or forbearing to show favour or disfavour to any person in relation to this or any other contract with the Employer.
 - (b) Any breach of this Condition by the Contractor or by anyone employed by him or acting on his behalf (whether with or without the knowledge of the Contractor) shall be an offence under the Laws of Kenya.

21. Settlement of Disputes:

- 21.1 Any dispute arising out of the Contract which cannot be amicably settled between the parties shall be referred by either party to the arbitration and final decision of a person to be agreed between the parties. Failing agreement to concur in the appointment of an Arbitrator, the Arbitrator shall be appointed by the chairman of the Chartered Institute of Arbitrators, Kenya branch, on the request of the applying party.

APPENDIX TO CONDITIONS OF CONTRACT

THE EMPLOYER IS: The Vice Chancellor,
 Kibabii University,
 P.O. Box 1699-50200,
 Bungoma.

The name (and identification number) of the project is: **Construction of The Proposed Women Student Hostel and Associated Works at Kibabii University.**

Tender No. KIBU/055/2016-2017

The Works consist of **Construction of The Proposed Women Student hostel and Associated Works at Kibabii University.**

The Start Date shall be **as notified by the Employer.**

The Intended Completion Date for the whole of the Works shall be **Forty (40) Weeks from date of site possession.**

The following documents also form part of the Contract: **add Notification of Award.**

The Site Possession Date shall be **as be as notified by the Employer.**

The Site is located **Within Kibabii University , off the Kanduyi-Chwele Road, Bungoma.**

The Defects Liability Period is **6 Months from Practical Completion date.**

Amount of Tender Security is **Two Percent of Tender Sum.**

The name and Address of the Employer's representative for the purposes of submission of tenders is:

The Vice Chancellor,
Kibabii University,
P.O. Box 1699-50200
Bungoma.

The tender opening date and time is **as per tender advert.**

The amount of performance security is **seven (7%) percent** of Tender Sum in form bank guarantee.

Liquidated and Ascertained damages: **at the rate of Ksh 50,000/= (fifty thousands) per week.**

Period of honouring certificate: **30 days**

Percentage of certified value retained: **10%**

Limit of certified value retained : **5%**

Period between program updates is: **14 days**

The amount to be withheld for late submission of an updated program is **1% of certified amount to be paid to the contractor.**

The Price Adjustment clause **SHALL NOT** apply

Advance payment **SHALL NOT** be granted

The rate of exchange for calculation of foreign currency payment is – **Not applicable**

The schedule of basic rates used in pricing by the contractor is as attached (contractor to attach).

Other contractors, utilities etc to be engaged by the employer on the site include those for the execution of:

- 1.....
- 2.....
- 3.....
- 4.....

The minimum insurance covers shall be:

- 1. Minimum cover for insurance of the works, plant and material in respect of the contractor’s faulty design is.....
- 2. The minimum cover for loss or damage to equipment is.....
- 3. The minimum for insurance of other property is.....
- 4. The minimum cover for personal injury or death insurance
 - For the contractor’s employee is.....
 - And for other people is.....

The following events shall also be compensation events:

- 1. Nil
- 2. Nil
- 3. Nil
- 4. Nil

SECTION C:

STANDARD FORMS

NOTE:

ALL FORMS IN THIS SECTION MUST BE FILLED WHERE APPLICABLE AS THEY SHALL BE PART OF THE EVALUATION CRITERIA

CONTENTS OF SECTION

TITLE	PAGE
1. Performance Bank Guarantee.....	42
2. Form of Agreement.....	43
3. Tender Questionnaire.....	44
4. Confidential Business Questionnaire.....	45
5. Key Personnel.....	47
6. Schedule of Contracts completed in the last eight (5) years.....	48
7. Schedule of on-going projects.....	49
8. Schedule of major items of contractor's equipment.....	50
9. Financial reports for the last five (5) years	51
10. Evidence of Financial Resources.	52
11. Name, Address and Telephone, Telex and Facsimile of Banks.	53
12. Draft Program of Works	54
13. Details of Litigation or Arbitrations	55
15. Anti-corruption affidavit form.....	56
16. Criminal offence disclosure.....	57

NOTE:

1.0 Tenderers must duly fill these Standard Forms as a mandatory requirement except item 1&2

2.0 Any tender returned with **unfilled Standard Forms** as indicated in 1.0 above shall be considered **non- responsive and shall automatically be disqualified.**

PERFORMANCE BANK GUARANTEE

To: The Vice Chancellor,
Kibabii University,
P.O. Box 1699-50200,
Bungoma.

Dear Sir,

WHEREAS(hereinafter called “the Contractor”) has undertaken, in pursuance of Contract No. dated to execute (hereinafter called “the Works”);

AND WHEREAS it has been stipulated by you in the said Contract that the Contractor shall furnish you with a Bank Guarantee by a recognized bank for the sum specified therein as security for compliance with his obligations in accordance with the Contract;

AND WHEREAS we have agreed to give the Contractor such a Bank Guarantee:

NOW THEREFORE we hereby affirm that we are the Guarantor and responsible to you, on behalf of the Contractor, up to a total of:

Kshs. (*amount of Guarantee in figures*)

Kenya Shillings (*amount of Guarantee in words*),

and we undertake to pay you, upon your first written demand and without cavil or argument, any sum or sums within the limits of Kenya Shillings

..... (*amount of Guarantee in words*) as aforesaid without your needing to prove or to show grounds or reasons for your demand for the sum specified therein.

We hereby waive the necessity of your demanding the said debt from the Contractor before presenting us with the demand.

We further agree that no change, addition or other modification of the terms of the Contract or of the Works to be performed thereunder or of any of the Contract documents which may be made between you and the Contractor shall in any way release us from any liability under this Guarantee, and we hereby waive notice of any change, addition, or modification.

This guarantee shall be valid until the date of issue of the Certificate of Completion.

SIGNATURE AND SEAL OF THE GUARANTOR

Name of Bank

Address

Date

FORM OF AGREEMENT

THIS AGREEMENT is made theday of
Between (hereafter called “the Employer”) of
the one part and of **P.O. BOX**
..... (hereafter referred to as “the Contractor”) of other part.

WHEREAS the Employer is desirous that the Contractor executes
.....(hereinafter called “the Works”) located in the, and
the Employer has accepted the tender submitted by the Contractor for the execution and
completion of such works and the remedying of any defects therein for the fixed Contract Price
of K.shs..... (Kenya Shillings)

NOW THIS AGREEMENT WITNESSETH AS FOLLOWS:

1. In this Agreement, words and expressions shall have the same meanings as are respectively assigned to them in the Conditions of Contract hereinafter referred to.
2. The following documents shall be deemed to form and shall be read and construed as part of this agreement i.e.
 - i. Letter of Notification of Award
 - ii. Letter of Acceptance
 - iii. Form of Tender
 - iv. Conditions of Contract and Appendix to Conditions of Contract.
 - v. Specifications
 - vi. Drawings
 - vii. Priced Bills of Quantities.
3. In consideration of the payments to be made by the Employer to the Contractor as hereinafter mentioned, the Contractor hereby covenants with the Employer to execute and complete the works and remedy any defects therein conformity to the provisions of the contract.
4. The Employer hereby covenants to pay the Contractor in consideration of the execution and completion of the works and the remedying of defects therein, the Contract price or such other sums as may become payable under the provisions of the Contract at the times and in the manner prescribed by the Contract.

IN WITNESS whereof the parties herein have caused this Agreement to be executed the day and year first before written.

The common seal of.....

Was hereunto affixed in the presence of.....

Signed sealed, and delivered by the said.....

Binding signature of Employer.....

Binding signature of the Contractor.....

In the presence of

(i) Name

Address.....

Signature.....

(ii) Name.....

Address.....

Signature.....

TENDER QUESTIONNAIRE

Please fill in block letters.

1. Full names of Tenderer:

.....

2. Full address of Tenderer to which tender correspondence is to be sent (unless an agent has been appointed below):

.....

3. Telephone number (s) of Tenderer:

.....

4. Telex/Fax Address of Tenderer:

.....

5. Name of Tenderer's representative to be contacted on matters of the tender during the tender period:

.....

6. Details of Tenderer's nominated agent (if any) to receive tender notices. This is essential if the Tenderer does not have his registered address in Kenya (name, address, telephone, telex):

.....

.....

Signature of Tenderer

CONFIDENTIAL BUSINESS QUESTIONNAIRE

You are requested to give the particulars indicated in Part 1 and either Part 2 (a), 2 (b) or 2(c) and (2d) whichever applies to your type of business.

You are advised that it is a serious offence to give false information on this Form.

Part 1 – General

Business Name

Location of business premises: Country/Town.....

Plot No..... Street/Road

Postal Address..... Tel No.....

Nature of Business.....

Current Trade Licence No..... Expiring date.....

Maximum value of business which you can handle at any time:
Kenya Shillings.....

Name of your bankers.....

Branch.....

Part 2 (a) – Sole Proprietor

Your name in full..... Age.....

Nationality..... Country of Origin.....

Citizenship details

Part 2 (b) – Partnership

Give details of partners as follows:

	Name in full	Nationality	Citizenship Details	Shares
1.
2.
3.
4.

Part 2(c) – Registered Company

Private or Public

State the nominal and issued capita of the company:

Nominal: KShs.

Issued: KShs.

Give details of all directors as follows:

	Name in full	Nationality	Citizenship Details*	Shares
1.
2.
3.
4.

Part 2(d) Interest in the Firm:

Is there any person/persons in the employment of the Government of Kenya WHO has interest in this firm? Yes/No If yes please give details.....

I certify that the above information is correct.

.....
Title

.....
Signature

.....
Date

*** Attach proof of citizenship**

KEY PERSONNEL

Qualifications and experience of key personnel proposed for administration and execution of the Contract. (Attach CV and copies of certificates which **MUST** be signed by owners of the certificate in blue ink and indicate telephone number(s))
 (Note: The persons herein indicated shall be subject to approval by the PM to administer the project.)

POSITION	NAME	HIGHEST QUALIFICATION	YEARS OF EXPERIENCE (GENERAL)	YEARS OF EXPERIENCE IN PROPOSED POSITION

I certify that the above information is correct.

.....
 Title

.....
 Signature

.....
 Date

CONTRACTS COMPLETED IN THE LAST FIVE (5) YEARS

Work performed on works of a similar nature, complexity and volume over the last 5 years. (Certified copies of Completion Certificates **MUST** be attached)

PROJECT NAME	NAME OF CLIENT	TYPE OF WORK AND YEAR OF COMPLETION	VALUE OF CONTRACT (Kshs.)

I certify that the above works were successfully carried out and completed by ourselves.

.....
Title

.....
Signature

.....
Date

SCHEDULE OF ON-GOING PROJECTS

Details of on-going or committed projects, including expected completion date.(Certified copies of Letters of Acceptance, Notification of Award or Contract Agreements **MUST** be attached)

PROJECT NAME	NAME OF CLIENT	CONTRACT SUM (KSHS)	% COMPLETE	COMPLETION DATE

I certify that the above works are currently being carried out by ourselves.

.....

 Title

.....
 Signature

Date

**SCHEDULE OF MAJOR ITEMS OF CONTRACTOR’S EQUIPMENT PROPOSED
FOR CARRYING OUT THE WORKS**

Details of contractor’s equipment to be used in carrying out the works. (Attach certified copies of log books, lease agreements or and other documentary evidence)

ITEM OF EQUIPMENT	DESCRIPTION, MAKE AND AGE (Years)	CONDITION (New, good, poor) and number available	OWNED, LEASED (From whom?), or to be purchased (From whom?)

FINANCIAL REPORTS FOR THE LAST FIVE YEARS
(Balance sheets, Profits and Loss Statements, Auditor's reports, etc.
List below and attach copies)

1. _____.
2. _____.
3. _____.
4. _____.
5. _____.
6. _____.
7. _____.
8. _____.
9. _____.
10. _____.

EVIDENCE OF FINANCIAL RESOURCES TO MEET QUALIFICATION REQUIREMENTS.

(Cash in Hand, Lines of credit, e.t.c. List below and attach copies of supportive documents.)

1. _____.
2. _____.
3. _____.
4. _____.
5. _____.
6. _____.
7. _____.
8. _____.
9. _____.
10. _____.

NAME, ADDRESS AND TELEPHONE, EMAILS OF BANKS

(This should be for banks that may provide reference if contacted by the Employer)

NAME	ADDRESS	TELEPHONE	EMAIL	FACSIMILE

DRAFT PROGRAM OF WORKS IN THE FORM OF A BAR CHART

DETAILS OF LITIGATIONS OR ARBITRATION PROCEEDINGS IN WHICH THE TENDERER IS INVOLVED AS ONE OF THE PARTIES (this form must be certified by commissioner of oaths)

1. _____.
2. _____.
3. _____.
4. _____.
5. _____.
6. _____.
7. _____.
8. _____.
9. _____.
10. _____.

Declaration.

**ANTI CORRUPTION AFFIDAVIT FORM
REPUBLIC OF KENYA**

**IN THE MATTER OF OATHS AND STATUTORY DECLARATION ACT CHAPTER 15
OF THE LAWS OF KENYA AND IN THE MATTER OF THE PUBLIC
PROCUREMENT AND ASSET DISPOSAL
ACT, 2015 (**

I, of P.O. Box being
a resident of in the Republic of Kenya do hereby make oath and state as
follows: -

- 1) THAT I am the; (Chief
Executive/Managing Director/Principal Officer /Director) of
..... (Name of the Business) which is a Candidate in respect of
Tender Number to (name of the works, goods, or service) and/or carry
out works for Kibabii University and duly authorized and competent to make this Affidavit.
- 2) THAT the aforesaid Candidate has not been **requested** to pay any inducement to any member
of the Board, Management, Staff and/or employees and/or agents of Kibabii University , which
is the procuring entity.
- 3) THAT the aforesaid Candidate, its servant(s) and/or agent(s) have not been **offered** THAT the
aforesaid Candidate has not been requested to pay any inducement to any member of the Board,
Management, Staff and/or employees and/or agents of Kibabii University , which is the
procuring entity.
- 3) THAT the aforesaid Candidate, its servant(s) and/or agent(s) have not been offered and will
not offer any inducement to any member of the Board, Management, Staff and/or employee(s)
and/or agent(s) of Kibabii University .
- 4) THAT the aforesaid Candidate, its servant(s) and/or agent(s) have not been debarred from any
procurement process.
- 5) THAT what is deposed to here in above is true to the best of my knowledge information and
belief.

SWORN at by the said }
..... } on this day of 20..... }

DEPONENT Before me } Commissioner for Oaths }

CRIMINAL OFFENCE DISCLOSURE

I/WE NAME OF DIRECTOR/DIRECTORS: -

A).....

(B).....

(C).....

Have not been convicted of any criminal offence relating to professional conduct or the making of false statements or misrepresentations as to its qualifications to enter into a procurement contract within a period of three years preceding the commencement of procurement proceedings.

Signed

For and on behalf of M/s

In the capacity of.....

Dated this day of.....2017

Suppliers/Company's rubber Stamp

Commissioner of oath.....

Dated this day of.....2017

Commissioners Company's rubber Stamp

SECTION D:
TENDER EVALUATION CRITERIA

TENDER EVALUATION CRITERIA

After tender opening, the tenders will be evaluated in 2 stages, namely:

1. Determination of Responsiveness
2. Financial Evaluation.

STAGE 1- DETERMINATION OF RESPONSIVENESS

A) PRELIMINARY EXAMINATION

This stage of evaluation shall involve examination of the pre-qualification conditions as set out in the Tender Advertisement Notice or Letter of Invitation to Tender and any other conditions stated in the bid document.

These conditions are:

- (i) Category of Registration with National Construction Authority in the relevant trade and or any other statutory bodies and the corresponding valid license.
- (ii) Valid Single Business Permit with relevant County Government.
- (iii) Current certified Tax Compliance Certificate issued by Kenya Revenue Authority.
- (iv) Company Certificate of Incorporation.
- (v) Provision of valid bid security.
- (vi) Completely filled Form of Tender.
- (vii) Submission of Two bid documents (clearly marked ‘**original**’ and ‘**copy**’)

The Employer may seek further clarification/confirmation if necessary to confirm authenticity/compliance of any condition of the tender.

The tenderers who do not satisfy any of the above requirements shall be considered Non-Responsive and their tenders will NOT be evaluated further.

B) TECHNICAL EVALUATION

The tender document shall be examined based on the Instruction to Tenderers which states as follows:

In accordance with Instruction to Tenderers, the tenderers will be required to provide evidence for eligibility of the award of the tender by satisfying the employer of their eligibility and adequacy of resources to effectively carry out the subject contract. The tenderers shall be required to fill the Standards Forms provided for the purposes of providing the required information. The tenderers may also attach the required information if they so desire.

The award of points in this section shall be as shown below;

<u>PARAMETER</u>	<u>MAXIMUM POINTS</u>
(i) Statement of Compliance -----	1
(ii) Tender Questionnaire - -----	1
(iii) Confidential Business Questionnaire -----	1
(iv) Key personnel - -----	14
(v) Contract Completed in the last Five (5) years - -----	9
(vi) Schedules of on-going projects -----	9
(vii) Schedules of contractors equipment -----	14
(viii) Audited Financial Report for the last 3 years-----	7
(ix) Evidence of Financial Resources -----	7
(x) Name, Address and Telephone of Banks (Contractor to provide) -----	1
(xi) Litigation History-----	2
(xii) Sanctity of the tender in documents -----	1
(xiii) Presentation of evidences and attachments in prescribed format-----	3
TOTAL	<u>70</u>

The detailed scoring plan shall be as shown in table 1 below: -

TABLE 1

Item	Description	Point Scored	Max. Point
i	Statement of Compliance Signed and stamped ----- 1 Not signed nor stamped -----0		1
ii	Tender Questionnaire Form Completely filled -----1 Not filled -----0		1
iii	Confidential Business Questionnaire Form. Completely filled ----- 1 Not filled ----- 0		1
iv	Key Personnel to be engaged on the project (Attach copies of certificates) Director of the firm <ul style="list-style-type: none"> ○ Holder of degree in Civil Engineering, Construction Technology, Architecture or Quantity Surveying--3 ○ Ditto with Diploma-----2 ○ Ditto with certificate-----1 ○ No relevant certificate -----0 At least 1 No. degree holder of key personnel in Civil Engineering/Quantity Surveying ,Construction Technology or Architecture. <ul style="list-style-type: none"> ○ With over 10 years relevant experience -----3 ○ With over 5 years relevant experience ----- 2 ○ With under 5 years relevant experience -----1 At least 2 No Diploma holder of key personnel in Civil Engineering/Construction Technology, Quantity Surveying or Architecture <ul style="list-style-type: none"> ○ With over 10 years relevant experience-----3 ○ With over 5 years relevant experience -----2 ○ With under 5 years relevant experience -----1 		14
	At least 2 No Certificate holder in Civil Engineering, Construction Technology, Quantity Surveying) With over 10 years relevant experience-----1 With under than 10 years' experience-----0		2

Item	Description	Point Scored	Max. Point
v	<p>Contract completed in the last five (5) years (A max of 3 No. Projects) Shall attach Completion Certificates.</p> <ul style="list-style-type: none"> ○ Project of similar nature and contract value of more than 100Million-----3 ○ Project of similar nature but of contract value less than 100million but more than 50million----- 2 ○ Project of similar nature but value less than 50million---1 ○ No project of similar nature-----0 		9
vi	<p>On-going projects (A max of 3 No. Projects) Shall attach Notification of award or Contract Agreements.</p> <ul style="list-style-type: none"> ○ Project of similar nature and contract value of more than 100Million-----3 ○ Project of similar nature but of contract value less than 100million but more than 50million----- 2 ○ Project of similar nature but value less than 50million---1 ○ No project of similar nature-----0 		9
vii	<p>Schedules of contractors equipment and transport (Shall attach proof or evidence of ownership by the company or director, if owned or and indicate the ability to lease (attach letter from the lessor), if leased)</p> <ul style="list-style-type: none"> ○ Concrete Hoist (at least 2No) Owned-----3 <ul style="list-style-type: none"> Leased -----1 Not provided-----0 ○ 0.5CM Concrete Mixer (at least 2No) Owned -----3 <ul style="list-style-type: none"> Leased -----1 Not provided-----0 ○ Dump Trucks/Lorries (at least 2 No) Owned -----3 <ul style="list-style-type: none"> Leased -----1 Not provided-----0 ○ Ten or three Tonne Drum Vibrating Roller Owned ----2 <ul style="list-style-type: none"> Leased -----1 Not provided-----0 ○ Any other relevant equipment to be used in the installation of the works tendered for. (Maximum No. of equipment to be considered 3No.) -3 		14

Item	Description	Point Scored	Max. Point
viii	<p>Annual audited financial reports (last three (3) years)</p> <ul style="list-style-type: none"> ○ At least one of the annual turnover greater or equal to 5 times the cost of the project ----- 7 ○ At least one of the annual turnover greater or equal to 3 times the cost of project ----- 5 ○ At one of the annual turnover greater or equal to the cost of the project -----3 ○ Annual turnover below the cost of the project----- 0 		7
ix	<p>Evidence of financial resources (cash in hand, lines of credit, overdraft facility etc) Cash in hand and lines of credit:</p> <ul style="list-style-type: none"> Of more than 30% of tender sum-----7 Of between 20% and 30% of tender sum----- 5 Of between 10% and 20% of tender sum----- 3 Below 10% of tender sum-----1 		7
x	<p>Name, address and telephone of banks (Contractor to provide)</p> <ul style="list-style-type: none"> ○ Provided and fully filled -----1 ○ Not provided----- 0 		1
xi	<p>Litigation History</p> <ul style="list-style-type: none"> ○ Filled and certified by commissioner of oaths ----2 ○ Not filled-----0 		2
xii	<p>Sanctity of tender documents</p> <ul style="list-style-type: none"> ○ Having the document intact (not tampered with in any way) -----1 ○ Having mutilated or modified the tender document--0 		1
xiii	<p>Presentation of evidences and attachments in prescribed format</p> <ul style="list-style-type: none"> ○ Arranged in prescribed format.....3 ○ Not arranged in prescribed format.....0 		3
	TOTAL TECHNICAL SCORE (TS)		70

Any bidder who scores 47 points and above shall be considered for further evaluation

STAGE 2 - FINANCIAL EVALUATION

The evaluation shall be in two sections

1. Preliminary examinations and
2. Tender sum Comparisons

1. Preliminary examinations.

The preliminary examination in the Financial Evaluation shall be in accordance with the Instruction to Tenderers.

The parameter to be considered under this section shall be arithmetic errors.

The bid shall be checked for arithmetic errors based on the rates and the total sums indicated in the bills of quantities.

Confirmation shall be sought in writing from the tenderers whose tender sums will be determined to have a significant arithmetic error to their disadvantage, to confirm whether they stand by their tender sums. The error shall be treated as per **Instructions to Tenderers**.

Non compliance with the above shall lead to **automatic disqualification from further evaluation**.

Discount if any shall be treated as an error in pursuant to Instructions to tenderers.

2. Tender Sum Comparisons.

TABLE 2

Item	Description	Score	Max. score
1	<p>Tender rates (The average of tender sums of the bidders including Engineer's Estimate less PCs Sums, provisional sums and contingency shall be worked out. The deviation of bidders tender Sum less PCs Sums, provisional sums and contingency from the average shall then be worked out as a percentage of the average and score allocated as follow:-)</p> <ul style="list-style-type: none"> ○ Deviation of between 0% to 5% -----15 ○ Deviation of between 5% to 10% -----12 ○ Deviation of between 10% to 15% -----9 ○ Deviation of between 15% to 20% -----6 ○ Deviation of between 20% to 25% -----3 ○ Deviation of between 25% to 30% -----1 ○ Deviation of above 30% ----- 0 		15
	TOTAL (Tender Sum Score)		15

The Financial Scores (FS) will be determined using the formulae below. The Financial Score will be allocated a maximum of 15%.

$$FS = 15 \times F_m/F$$

Where FS is the Financial Score, F_m is the lowest priced responsive financial bid and F is the price of the bid under consideration.

The Total Financial Score = Tender Sums Score + Financial Score = 30%

CONCLUSION

COMBINATION OF TECHNICAL AND FINANCIAL SCORE

The evaluation team shall combine Technical and Financial Score as below:

Technical score (TS) + Total Financial score (TFS) = 70% + 30%

RECOMMENDATION.

The combined technical and total financial score shall be determined and tenderers ranked. The evaluation committee shall conduct a due diligence on the tenderer with the highest score to establish the validity of information given in his tender document before award of tender. If the committee finds out that the highest tenderer cannot validate the documents in his tender document the committee shall conduct a due diligence on the second ranked tenderer with the second highest score to establish validity of information given in his bid document before award of tender. If the committee finds out that the second highest score tenderer cannot validate the documents in his tender, the evaluation committee shall recommend tender under consideration re tendered.

ARRANGEMENT OF ATTACHED AND STATUTORY DOCUMENTS

All tenderers shall arrange all attached evidences and statutory documents in the following order;

1. Bid security
2. Pin certificate
3. VAT certificate
4. Tax compliance certificate
5. Valid County government trade license
6. Company certificate of incorporation.
7. NCA registrations certificate and valid license
8. Tender Questionnaire attachments
9. Confidential Business Questionnaire attachments
10. Key Personnel attachments
11. Schedule of Contracts completed in the last eight (5) years attachments
12. Financial reports for the last five (5) years attachments
13. Schedule of major items of contractor's equipment attachments
14. Schedule of on-going projects attachments
15. Evidence of Financial Resources attachments
16. Name, Address and Telephone, Telex and Facsimile of Banks attachments.
17. Draft Program of Works attachments.
18. Details of Litigation or Arbitrations attachments.

SECTION E:
BILL OF QUANTITIES

PREAMBLE AND NOTES TO BILLS OF QUANTITIES

1. These Bills of Quantities form part of the Contract Documents and are to be read in conjunction with the conditions of Contract, Standard and Special Specification and Drawings.
2. The quantities set forth in the Bills of Quantities are believed to represent the character of the work to be carried out. There is no guarantee to the Contractor that he will be required to carry out the quantities of work indicated under any one particular item or group of items in the Bills of Quantities, though on the Contract as a whole the quantities are believed to represent the overall value of the work to be carried out.
3. The prices and rates inserted in the Bills of Quantities will be used for valuing the work executed and the Engineer will measure the whole of the works executed in accordance with the Contract.
4. The prices and rates inserted in the bills of quantities are to be the full inclusive costs of the works described under the items, complete in place and in accordance with the Specification and Drawings including costs and expenses which may be required in and for the construction of the works described, together with any temporary works and installations which may be necessary and all general risks, liabilities and obligations set forth or implied in the Documents on which the Contract is based.
5. The brief description of the items given in the Bills of Quantities are purely for the purpose of identification and in no way modify or supersede the detailed descriptions given in the Conditions of the Contract, Specifications or Drawings and Special Specification for the full directions and descriptions of work and materials.
6. A price or rate is to be inserted, in ink against each item in the Bills of Quantities, whether quantities are stated or not, and if the Tenderer includes the cost of a particular item elsewhere in his rates or prices, he shall insert in the word “nil” against both the rate and extension of that particular item. Should the Tenderer omit to price an item, then it will be assumed that he has included the cost of the item elsewhere in his rates or prices.
7. No alteration shall be made to the Bills of Quantities and no extra item shall be inserted. The Tenderer shall satisfy himself that the Contract Sum arrived at by pricing the

- quantities and items given is sufficient compensation for constructing and maintaining the whole of the works in accordance with the Contract Documents.
8. For the purpose of payment by Interim Certificate of “Lump Sum” items the Engineer may assess the portion of the work completed on the “Lump Sum” items and allow for payment the portion of the “Lump Sum” he deems fair and reasonable. The total of all portions allowed shall not exceed the “Lump Sum”. All interim payments shall be subject to the retention stipulated in the Contract Documents.
 9. During construction the unit rate established for an item in one Bill of Quantities may be used as a basis for establishing a unit rate for similar work in another Bill of Quantities which contains no unit rate for the said item.
 10. The Contractor will be provided by Employer with all that land occupied by the Permanent Works including the specified working width for pipe laying and the costs of compensation and entry upon land will be paid from Provisional Sums.
 11. It shall be the responsibility of the Contractor to arrange for the removal of, or alteration to, services where necessitated by the Works. Incurred costs being paid by the Employer.
 12. Quantities for site clearance stripping and spreading shall be based on the horizontal projection of the area cleared or stripped.
 13. The rates for excavation items shall include inter alia for setting aside spoil for reuse in the Works or disposing to approved tips, except where otherwise provided for in the Bills of quantities.
 14. Generally, the excavation items are based on volume for structures and on linear measurement for certain pipelines. One or more items may cover the works. The rates shall include as appropriate for:-
 - a) Breaking through surfaces; handling different classes of material separately: excavation beyond the net plan area of the foundations for working space and for battering or timbering etc
 - b) Timbering
 - c) Dealing with water
 - d) Backfilling as specified
 - e) Disposal of surplus spoil

Measurement of the volume in pipe trench will be measured from ground level to the invert of the trench. Measurement for other excavations will be to the size which is required to accommodate the permanent work. A tenderer shall accordingly allow in his prices for any amount of extra excavation which may be necessary for working space to complete the work to the satisfaction of the Engineer.

Items are included for "Extra for Rock" on a volume basis. The rates shall include for Breaking out and any other additional costs and the items shall apply to work encountered within measured excavation. Different classifications may be billed separately. Rock shall be measured as a volume calculated from the thickness encountered within the plan area of a mass excavation, within the plan dimensions of a structure, or within the notional width of a trench. Timbering left in excavations shall only be measured for payment where it is specified or ordered by the Engineer.

15. When the site of any particular item of Works has been sufficiently cleared of trees, undergrowth etc. and before any excavation or filling has been carried out, the Contractor shall carry out survey under the supervision of Engineer's Representative to take, record and agree adequate ground levels. The data so obtained shall be used as a basis for the computation of excavation and filling.
16. The volume of fill will be measured net to the finished levels as shown on the drawings or as amended by the Engineer.
17. All reinforcement will be paid for on the basis of its computed weight except for reinforcement that will be paid for on the basis of the area placed. The unit rates inserted in the Bills of Quantities shall include for all necessary cutting, bending and fixing, and all additional bars which may be required as spacer supports and lacings and also for all soft iron tying wires, fixing clips of approved pattern and manufacture and chairs. The cost of all temporary works including clips, chairs etc. shall be included in the rates for the reinforcing steel.
The weight for reinforcing bars shall include for all hooked or bent ends as per the bending schedule. Rates for fabric reinforcement or other reinforcement shall include for all laps, cuttings to size, bending and waste.

18. The rates for concrete shall include for making and testing preliminary test cubes, for making works test cubes and forwarding them to the Testing Engineer, forming the concrete to the slopes and falls shown on the drawings and any additional concrete used in excess of the net requirements. The rates shall also include for forming construction joints, for protection, for curing, for the rubbing down of exposed surfaces of concrete after removal of formwork and for floating or brushing of other exposed surfaces where this is required.

19. The rates for precast concrete paving shall include for all cutting, bending, jointing and laying to falls.

20. The rates for precast concrete edging and kerbs shall include for formwork, concrete bed and backing, all cutting, bedding, jointing and laying to falls.

21. The rates for formwork shall include for fillets and chamfers up to 50mm wide on the spay, coating to prevent adherence of concrete and the provision of temporary openings to facilitate inspection and cleaning. Rates shall also be inclusive of all necessary box outs and cut outs for holes up to 1 square metre.

The rates for forming rebates in concrete walls etc shall include for forming pockets for the fish tail fixing cleats where required. Deductions from formwork quantities will be made for openings more than 1 square metre in area.

22. Formwork for upper surfaces inclined at 15 degrees or less to the horizontal is not measured and the cost of any such formwork used will be deemed to be included in the relevant concrete item rate.

23. Wrought formwork where specified will be measured to 150mm below final ground level.

Abbreviations

E.O	-	Extra Over
Avg	-	Average
Max	-	Maximum
Min	-	Minimum
n.e.	-	Not Exceeding
mm	-	Millimetres
lm	-	Linear Metres
sm	-	Square Metres
cm	-	Cubic Metres
Ha	-	Hectares
No	-	Number
Drg.	-	Drawing
Kg	-	Kilogramme
H.T.	-	High Tensile
M.S.	-	Mild Steel
B.L	-	Bitumen Lined
C.I.	-	Cast Iron
D.I.	-	Ductile Iron
UPVC	-	Unplasticised Polyvinyl Chloride
G.I.	-	Galvanized Iron
G.M.S.	-	Galvanized Mild Steel
P.E.H.	-	Palothene
Hr.	-	Hour

31. The rates for metal work shall include for bolts, nuts, washers and rawl bolts, fixing as Specified or in accordance with the manufactures instructions and rectifying as specified any parts of the painted, coated or galvanized surface that may be damaged either before or after erection.

32. The rate for fixing penstocks and flap valves etc. shall include for bedding and grouting, testing for water tightness, greasing all working parts and leaving in good working order: where the item includes supply, the rates shall also include for supplying drawings for approval before manufacture is commenced.

Sewers, Drains and Pipelines

The rates for pipes, pipe work specials shall include for supply of all materials, setting of concrete blocks and hardwood wedges where specified, provide any temporary support that may be necessary, preparing ends of pipes for jointing and all labour in jointing, protection to detachable joints, cleaning pipelines and rectifying as specified any damage to surface coating. The rates shall also include for all cutting of pipes consequent upon structures, specials and fittings being construction in the designated positions.

33. The rates for concrete surround, bed and haunching to pipes, concrete in anchor blocks to pipes, and to gully pots shall include for all formwork required and for any additional concrete the Contractor may place for his own convenience or by reason of the method or carrying out the work.

Prime Cost Items

34. Attendance on nominated Sub-Contractors shall include for all or any of the following as appropriate; labour, materials and plant required for taking delivery, carting, storing, hoisting and builders work entailed in fixing, erecting and installing as specified or in accordance with the manufactures instructions and all overheads and profits.
35. When, in the opinion of the Engineer, it is reasonable to expect the Contractor to price the attendance item it will be so included in the Bills of Quantities in all other cases it will form the subject of a Provisional Sum to be expended on a Day works basis.
36. Profit shall include for establishment charges, profit and any other costs not included in the attendance item.

The rates for the supply for any mechanical and electrical equipment shall include for witnessed works as directed by the Engineer.

- a) *Provide* –shall mean all costs to cover purchase of materials in good condition, services for transaction with supplier, supervision, and transport to site or works all charges for rental, consumptions, overheads and profits throughout the Contract. It shall also include for all maintenance, insurance, handling and storage whenever applicable.

- b) *Excavate for*- shall mean handling of any material from its incumbent position intended for specified work shown in the drawings or directed by the Engineer and backfilling and compacting part of material after laying of pipes, and cart away remaining to tips to be provided by the Contractor. The cost for this work shall include all survey, supervision, labour, tools machinery, protection of work, pumping, insurances and overheads and profits.
- c) *Laying*'- shall cover all work necessary for placing an object or materials to true line and level and level specified in a drawing or as directed by the Engineer.
- d) *Jointing*'- shall mean process of fixing specified material, pipes, fittings and specials together using appropriate tools, materials, labour and machinery. It should cover for all work necessary to provide matching of opposite parts in size, shape, and position indicated and clamps, settings and holders to hold firmly.
- e) *Testing*'-shall mean provision of all materials, apparatus, labour, machinery, charges for the media or chemical to be used and their transport, repair of object to be tested if required, re-testing, excavation of any part for visual inspection, erection of any type all until the object has been certified as having passed the required test satisfactorily.
- f) *Install*'-shall include for all work requirements stipulated for "laying and jointing"

38. Government Taxes

- a) Tenderers to include in their rates for 16% V.A.T., all duties and other statutory taxes as no claim on the same shall be allowed.
- b) Tenderers should note that the Employer will deduct 3% of the contract being withholding tax and will be remitted directly to the commissioner of Income Tax.

39. Pricing of Preliminaries Items.

Prices will be inserted against item of preliminaries in the contractor's Bills of Quantities and specification. Where the contractor fails to insert his price in any item he shall be deemed to have made adequate provision for this on various items in the Bills of Quantities. The preliminaries form part of this contract and together with other Bills of Quantities covers for the costs involved in complying with all the requirements for the proper execution of the whole of the works in the contract.

40. **Statement of Compliance**

- a) I confirm compliance of all clauses of the General Conditions, General Specifications and Particular Specifications in this tender.

- b) I confirm I have not made and will not make any payment to any person, which can be perceived as an inducement to win this tender.

Signed:*for and on behalf of the Tenderer*

Date:

Official Rubber Stamp:

DRAWINGS

1. Drawing 01- Wardrobes Details.
2. Drawing 02- Spiral Stairs Details.
3. Drawing 03- Students' Beds.
4. Drawing 04- Reading Tables.
5. Drawing 05- Students Chairs

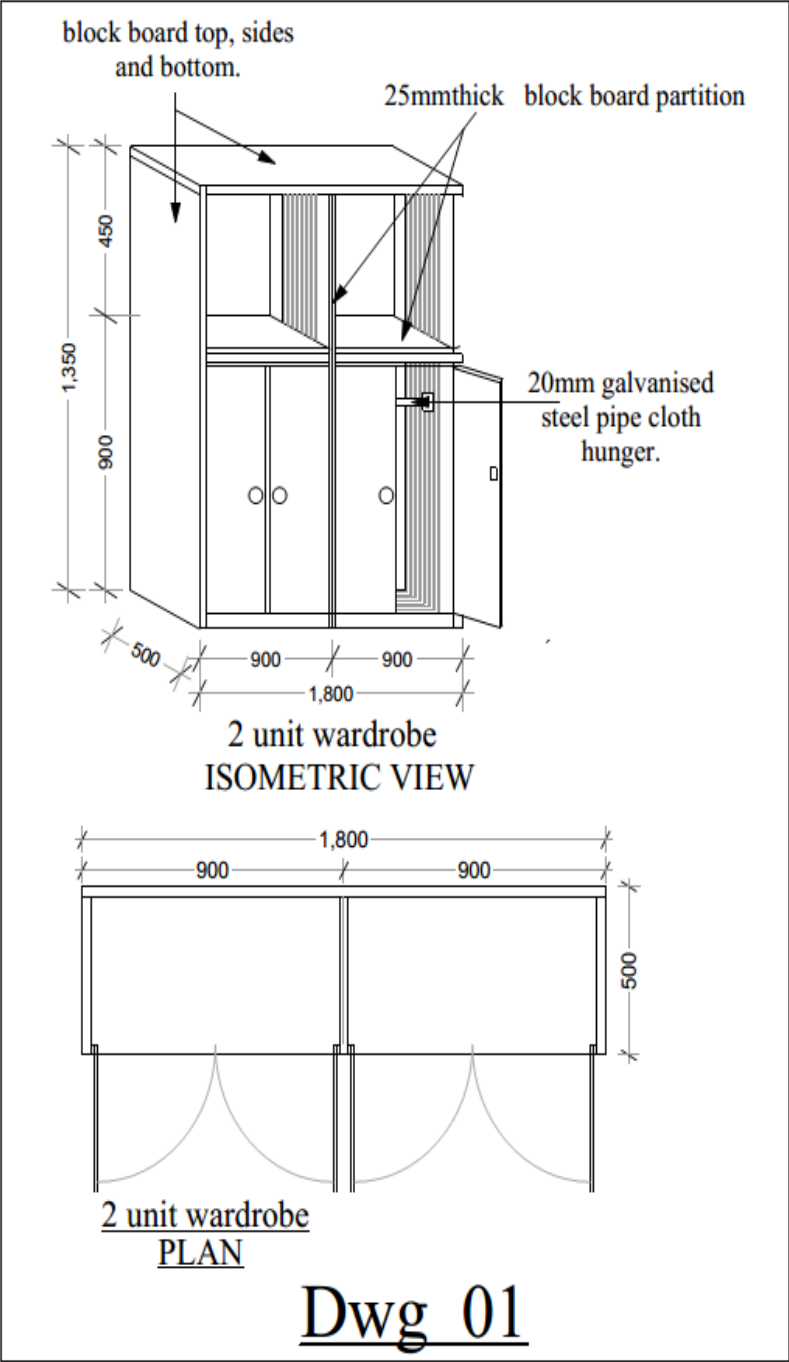

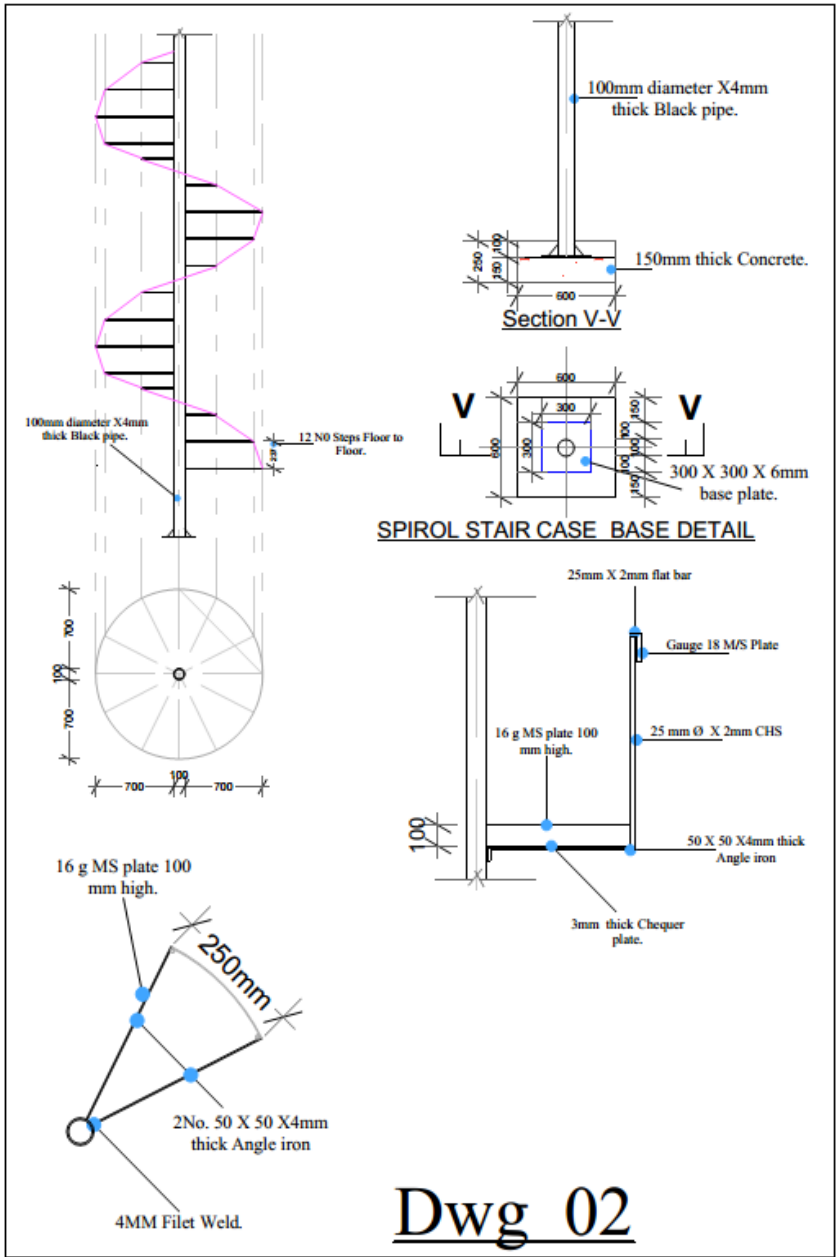

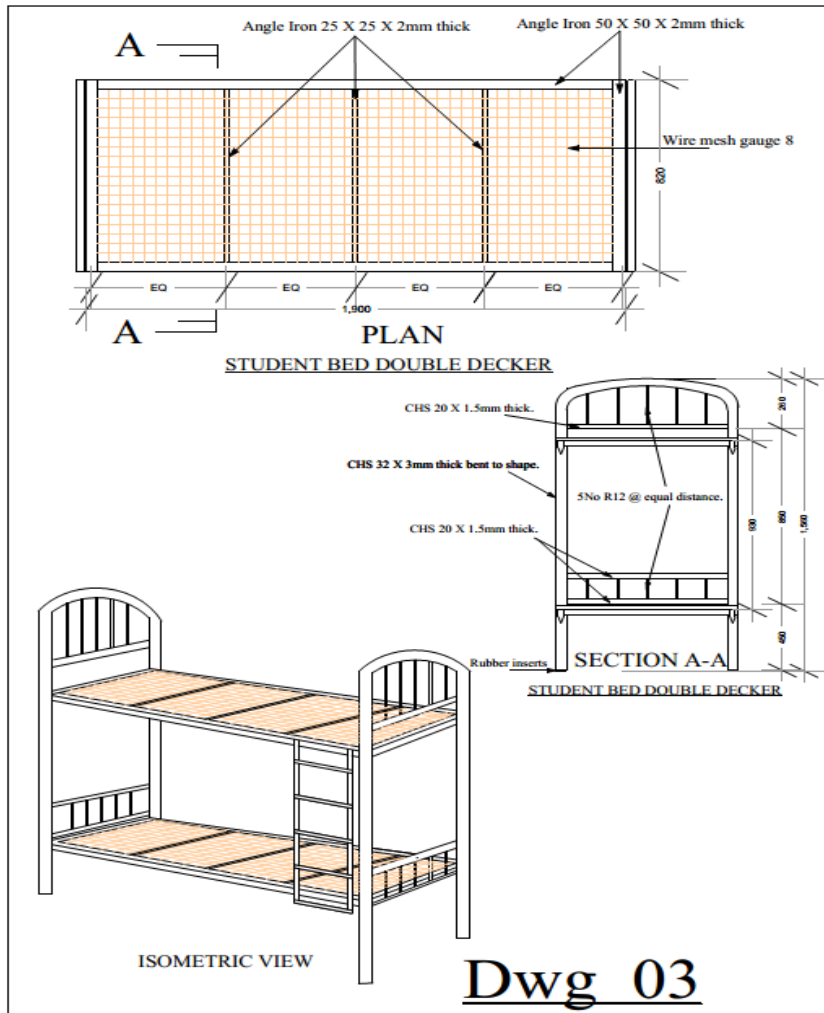

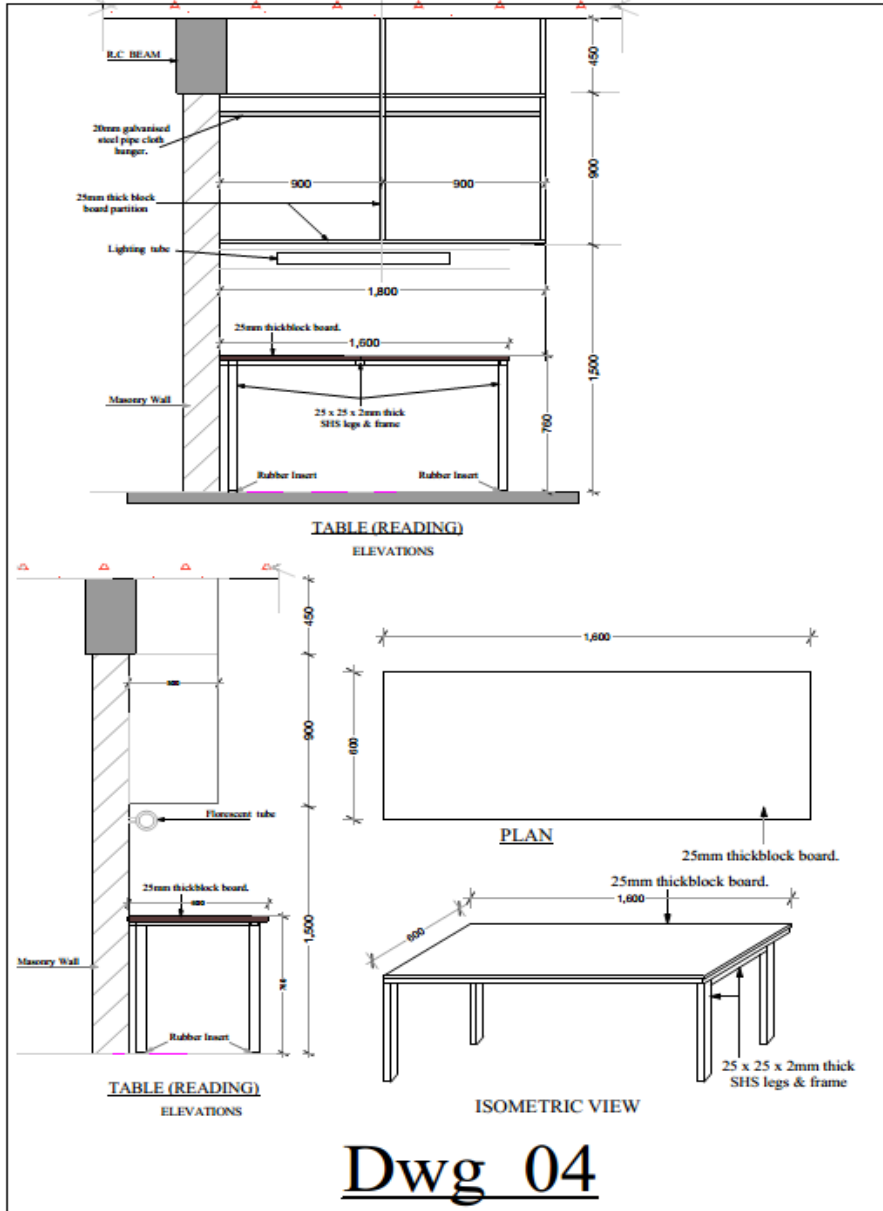

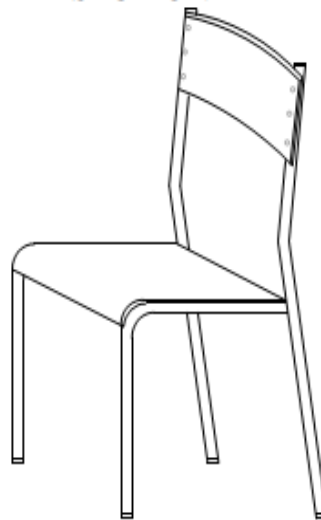
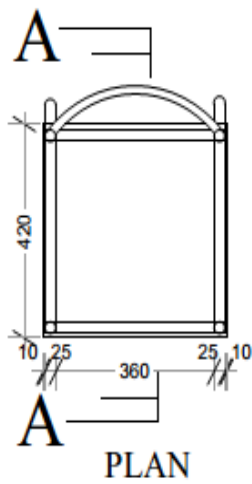
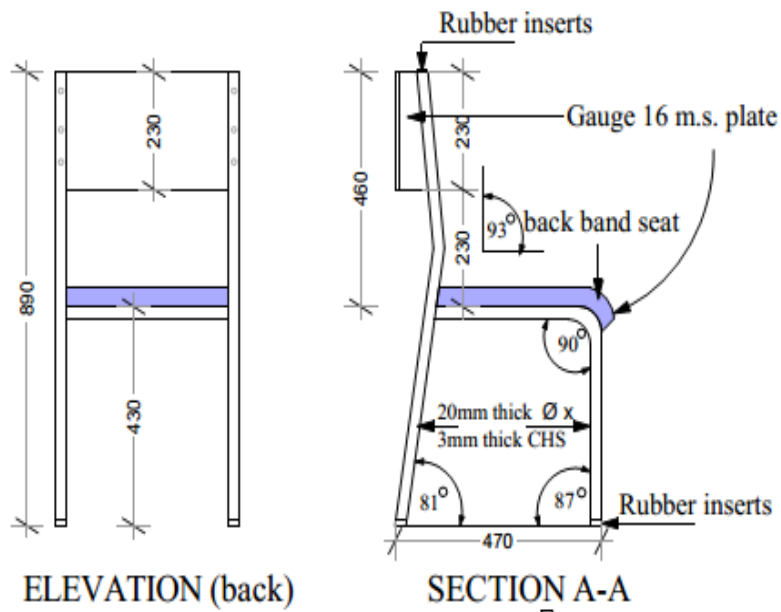

STUDENT READING CHAIR

Dwg 05

ARRANGEMENT OF ATTACHED AND STATUTORY DOCUMENTS

All tenderers shall arrange all attached evidences and statutory documents in the following order;

19. Bid security
20. Pin certificate
21. VAT certificate
22. Tax compliance certificate
23. Valid County government trade license
24. Company certificate of incorporation.
25. NCA registrations certificate and valid license
26. Tender Questionnaire attachments
27. Confidential Business Questionnaire attachments
28. Key Personnel attachments
29. Schedule of Contracts completed in the last eight (5) years attachments
30. Financial reports for the last five (5) years attachments
31. Schedule of major items of contractor's equipment attachments
32. Schedule of on-going projects attachments
33. Evidence of Financial Resources attachments
34. Name, Address and Telephone, Telex and Facsimile of Banks attachments.
35. Draft Program of Works attachments.
36. Details of Litigation or Arbitrations attachments.